

**RS-449/530/MIL  
DATA INTERFACE  
(MODEL 41400)  
OPERATING MANUAL**

**JUNE 1999**

This manual applies to all serial numbers, unless specified otherwise.



Copyright 1999 TTC®  
20400 Observation Drive, Germantown, Maryland 20876-4023 USA  
USA 1-800-638-2049 • +1-301-353-1550 (MD) • FAX +1-301-353-0234  
Canada 1-888-689-2165 • +1905-507-4117 • FAX +1-905-507-4126  
[www.ttc.com](http://www.ttc.com)



# TABLE OF CONTENTS

SECTION	PAGE
<b>1.0 GENERAL INFORMATION</b> .....	<b>1</b>
1.1 INTRODUCTION .....	1
1.2 SAFETY CONSIDERATIONS .....	1
1.3 ENVIRONMENTAL CONSIDERATIONS .....	1
1.4 INTERFACE FEATURES .....	1
1.5 INTERFACE CAPABILITY .....	2
1.6 OPTIONS AND ACCESSORIES .....	2
<b>2.0 INTERFACE DESCRIPTION</b> .....	<b>3</b>
2.1 INTRODUCTION .....	3
2.2 PHYSICAL DESCRIPTION REQUIREMENTS .....	3
2.3 FUNCTIONAL DESCRIPTION .....	5
2.4 MAINFRAME OPERATION WITH THE RS-449/530/MIL INTERFACE .....	7
<b>3.0 FIREBERD 4000 INSTALLATION AND OPERATION</b> .....	<b>11</b>
3.1 INTRODUCTION .....	11
3.2 INSTALLING THE INTERFACE .....	11
3.3 FIREBERD 4000 INTERFACE SET-UP .....	12
3.4 FIREBERD 4000 ANALYSIS RESULTS .....	20
3.5 FIREBERD 4000 SELF-LOOP TEST .....	21
3.6 INTERFACE STATUS INDICATORS AND SWITCHES .....	21
3.7 FIREBERD 4000 PRINTER OPERATION .....	21
3.8 FIREBERD 4000 REMOTE CONTROL COMMANDS .....	23
<b>4.0 FIREBERD 4000 APPLICATIONS</b> .....	<b>25</b>
4.1 INTRODUCTION .....	25
4.2 SYNCHRONOUS TESTING .....	25
4.3 ASYNCHRONOUS TESTING .....	30
<b>5.0 FIREBERD 6000 INSTALLATION AND OPERATION</b> .....	<b>33</b>
5.1 INTRODUCTION .....	33
5.2 INSTALLING THE INTERFACE .....	33
5.3 FIREBERD 6000 MAINFRAME SET-UP .....	34
5.4 FIREBERD 6000 INTERFACE SET-UP .....	34
5.5 FIREBERD 6000 ANALYSIS RESULTS .....	39
5.6 FIREBERD 6000 SELF LOOP TEST .....	41
5.7 INTERFACE STATUS INDICATORS AND SWITCHES .....	41
5.8 FIREBERD 6000 PRINTER OPERATION .....	41
5.9 FIREBERD 4000 REMOTE CONTROL COMMANDS .....	42
<b>6.0 FIREBERD 6000 APPLICATIONS</b> .....	<b>43</b>
6.1 INTRODUCTION .....	43
6.2 SYNCHRONOUS TESTING .....	43
6.3 ASYNCHRONOUS TESTING .....	47
<b>7.0 INTERFACE SPECIFICATIONS</b> .....	<b>51</b>
7.1 INTRODUCTION .....	51
<b>8.0 MAINTENANCE AND SERVICE</b> .....	<b>53</b>
8.1 INTRODUCTION .....	53
8.2 MAINTENANCE .....	53
8.3 SERVICE .....	53
<b>APPENDIX A RS-449/530/MIL DATA INTERFACE FACTORY DEFAULTS</b> .....	<b>55</b>

## TABLE OF CONTENTS (Continued)

FIGURES	PAGE
2-1 THE RS-449/530/MIL DATA INTERFACE .....	3
2-2 DIP SWITCH FACTORY SETTINGS .....	7
2-3 FIREBERD 4000 EMULATING SYNCHRONOUS DTE .....	8
2-4 FIREBERD 4000 EMULATING SYNCHRONOUS DCE .....	9
3-1 INSTALLING A MODULAR INTERFACE .....	11
3-2 FIREBERD 4000 RS-449/530/MIL DATA INTERFACE SETUP MENU TYPE RS-449 D-TYPE .....	13
3-3 FIREBERD 4000 RS-449/530/MIL DATA INTERFACE SETUP MENU TYPE RS-449 TWINAX .....	14
3-4 FIREBERD 4000 RS-449/530/MIL DATA INTERFACE SETUP MENU TYPE 188/114 D-TYPE .....	15
3-5 FIREBERD 4000 RS-449/530/MIL DATA INTERFACE SETUP MENU TYPE 188/114 TWINAX .....	16
3-6 FIREBERD 4000 RS-449/530/MIL DATA INTERFACE SETUP MENU TYPE 188C .....	17
3-7 FIREBERD 4000 RS-449/530/MIL DATA INTERFACE SETUP MENU TYPE EIA530 .....	18
3-8 CONTROLS PRINTOUT .....	22
3-9 LONG RESULTS PRINTOUT .....	22
4-1 LOCAL AND REMOTE LOOPBACK TESTING .....	25
4-2 TESTING A FAR-END SUBRATE CHANNEL .....	26
4-3 TESTING NEAR- AND FAR-END SUBRATE EQUIPMENT SIMULTANEOUSLY .....	28
4-4 TESTING AN ASYNCHRONOUS MODEM .....	30
5-1 INSTALLING A MODULAR INTERFACE .....	33
5-2 FIREBERD 6000 RS-449/530/MIL DATA INTERFACE SET-UP MENU TYPE 188114 .....	35
5-3 FIREBERD 6000 RS-449/530/MIL DATA INTERFACE SET-UP MENU TYPE EIA530 .....	36
5-4 FIREBERD 6000 RS-449/530/MIL DATA INTERFACE SET-UP MENU TYPE RS-449 .....	37
5-5 FIREBERD 6000 RS-449/530/MIL DATA INTERFACE SET-UP MENU TYPE 188C .....	38
5-6 CONTROLS PRINTOUT .....	41
5-7 RESULTS PRINTOUT .....	42
6-1 LOCAL AND REMOTE LOOPBACK TESTING .....	43
6-2 TESTING A FAR-END SUBRATE CHANNEL .....	44
6-3 TESTING NEAR- AND FAR-END SUBRATE EQUIPMENT SIMULTANEOUSLY .....	46
6-4 TESTING AN ASYNCHRONOUS MODEM .....	47

### TABLES

2-1 RS-449/530/MIL INTERFACE PIN CONNECTIONS .....	4
2-2 TWINAX CONNECTOR REFERENCES .....	5
3-1 FIREBERD 4000 ANALYSIS RESULTS .....	20
3-2 RS-449/530/MIL FIREBERD 4000 DATA INTERFACE REMOTE CONTROL COMMANDS .....	23

**TABLE OF CONTENTS**  
**(Continued)**

<b>TABLES</b>	<b>PAGE</b>
4-1 FIREBERD 4000 SYNCHRONOUS TEST SET-UP WITH EIA-530 .....	26
4-2 FIREBERD 4000 SYNCHRONOUS TEST SET-UP WITH RS-449 .....	28
4-3 FIREBERD 4000 SYNCHRONOUS TEST RESULTS .....	30
4-4 FIREBERD 4000 ASYNCHRONOUS TEST SET-UP WITH 188C .....	31
4-5 FIREBERD 4000 ASYNCHRONOUS TEST RESULTS .....	32
5-1 FIREBERD 6000 ANALYSIS RESULTS .....	40
5-2 RS-449/530/MIL DATA INTERFACE FIREBERD 6000 REMOTE CONTROL COMMANDS .....	42
6-1 FIREBERD 6000 SYNCHRONOUS TEST SET-UP WITH EIA-530 .....	44
6-2 FIREBERD 6000 SYNCHRONOUS TEST SET-UP WITH RS-449 .....	46
6-3 FIREBERD 6000 SYNCHRONOUS TEST RESULTS .....	48
6-4 FIREBERD 6000 ASYNCHRONOUS TEST SET-UP WITH 188C .....	49
6-5 FIREBERD 6000 ASYNCHRONOUS TEST RESULTS .....	50
7-1 RS-449/530/MIL DATA INTERFACE SPECIFICATIONS .....	51
A-1 DATA INTERFACE DEFAULT SETTINGS .....	55



## GENERAL INFORMATION

### 1.1 INTRODUCTION

This manual contains descriptions, setup and operating instructions, specifications, maintenance, and service information for the TTC (Telecommunications Techniques Corporation) Model 41400 RS-449/530/MIL Data Interface. The RS-449/530/MIL Data Interface allows the FIREBERD 4000 (Rev 3 and above) and FIREBERD 6000 (Revision G software and above) to be connected to RS-449, MIL-188-114, EIA-530, MIL-188C and compatible circuits and to act as a DTE or DCE device in balanced or unbalanced mode.

### 1.2 SAFETY CONSIDERATIONS

The following safety considerations should be observed:

- Use a grounding strap when removing or installing this interface.
- Ensure that power is off when removing or installing this interface.
- Remove or install the RS-449/530/MIL Data Interface, Model 41400, in a moisture free environment.
- Make sure the RS-449/530/MIL Data Interface, Model 41400, is used with well grounded equipment.
- Always wear safety equipment appropriate for the job, such as eye protection.
- Never operate the equipment when combustible gases or fluids are present.

### 1.3 ENVIRONMENTAL CONSIDERATIONS

The RS-449/530/MIL Data Interface, Model 41400, should be operated in a non-combustible atmosphere. There should be no flammable materials in the area. This RS-449/

530/MIL Data Interface, Model 41400, and associated equipment, is sensitive to corrosive materials, including exposure to salt. This unit is not waterproof.

### 1.4 INTERFACE FEATURES

The RS-449/530/MIL Data Interface has the following features.

- Compatible with RS-449, MIL-188-114, EIA-530, and MIL-188C standards.
- Emulate DTE or DCE.
- Circuit connections using either the 25-pin D-type, 37-pin D-type, or twinax connectors.
- Operates in balanced or unbalanced interface mode.
- User selectable terminating impedance.
- Test in synchronous timing up to 15 Mb/s.
- Test in asynchronous timing up to 20 kb/s.
- Test in recovered timing up to 520 kb/s. (FIREBERD 6000 with clock recovery option.)
- Controlled through the FIREBERD front panel Interface Setup menu or by remote control.
- Control RL and LL lines while emulating DTE and TM and CTS lines while emulating DCE.
- Select ground termination technique on receive clock and receive data lines.
- Set the polarity of all interface signaling control leads.

## 1.5 INTERFACE COMPATIBILITY

The RS-449/530/MIL Data Interface is designed in consideration with the following publications and specifications.

- CCITT Recommendation V.10 (or X.26), Electrical Characteristics of Unbalanced Double-Current Interchange Circuits.
- CCITT Recommendation V.11 (or X.27), Electrical Characteristics of Balanced Double-Current Interchange Circuits.
- EIA RS-422-A, December 1978, Electrical Characteristics of Unbalanced Voltage Digital Interface Circuits.
- EIA RS-423-A, December 1978, Electrical Characteristics of Unbalanced Voltage Digital Interface Circuits.
- EIA RS-449, November 1977, General Purpose 37-Position Interface for DTE and DCE Terminating Equipment.
- EIA-530, 18 March 1987, High Speed 25-Position Interface for DTE and DCE Terminating Equipment.
- ISO 4902-1980 (E), Data communication -37-pin and 9-pin DTE/DCE Interface Connectors and Pin Assignments.
- MIL-STD-188-114, March 1976, Electrical Characteristics of Digital Interface Circuits Standard.
- MIL-STD-188-100, 15 November 1972, Common Long Haul and Tactical Communication System Technical Standards.
- MIL-STD-188C, 1969, Military Communications Technical Standard.

## 1.6 OPTIONS AND ACCESSORIES

The following cables are available from TTC for the RS-449/530/MIL Interface Adapter.

- Model 10562, 6' RS-449 DTE 37-pin D to X.21 DTE 15-pin.
- Model 10213, 6' RS-232/EIA-530/V.24 male-to-male connectors.
- Model 10418, 10' RS-232/EIA-530/V.24 male-to-male connectors.
- Model 10215, 6' RS-449/530/MIL-188 37-pin D, male-to-male cable.
- Model 10417, 10' RS-449/530/MIL-188 37-pin D, male-to-male cable.
- Model 10496, 6' MIL-188 male 37-pin D to male 25-pin D cable.
- Model 10538, 6' MIL-188 male 37-pin D to female 25-pin D cable.
- Model 30917, 10' concentric Twinax, 124 ohm.



## INTERFACE DESCRIPTION

### 2.1 INTRODUCTION

The RS-449/530/MIL Data Interface is selected and configured from the FIREBERD mainframe using the INTERFACE SETUP category or from a computer. The RS-449/530/MIL Data Interface menu remote control are discussed in Section 4 for the FIREBERD 4000 and FIREBERD 6000 Reference Manuals.

This section contains a functional description of each of the RS-449/530/MIL Data Interface capabilities and features.

### 2.2 PHYSICAL DESCRIPTION REQUIREMENTS

The RS-449/530/MIL Data Interface has one 37-pin D-type connector and one 25-pin D-type connector. See Figure 2-1. Both connectors can be configured as either a DTE or DCE device through the interface setup menu. The

37-pin D-type connector (RS-449, MIL-188-114) and the 25-pin D-type connector (EIA-530, MIL-188C) provide access to any RS-449, MIL-188-114, EIA-530, or MIL-188C compatible circuit. The corner pins of each connector are labeled with the appropriate pin number. See Table 2-1 for descriptions on the pin outs for each connector.

In addition to the two D-type connectors the interface has five twinax connectors labeled RCV DATA, RCV CLK, TX DATA, TX CLK OUT, and EXT TX CLK IN which allow the FIREBERD to test a wide variety of data handling devices. See Table 2-2 for twinax connector references.

A six-position DIP switch is accessible on the side panel of the interface. The DIP switch allows for type of ground termination to be selected for the Receive Clock, Receive Data, and the external Transmit Clock.

**NOTE:** The 25-pin D-type, 37-pin D-type, and the twinax connectors are all wired in parallel. Connect only one type of connector at a time.

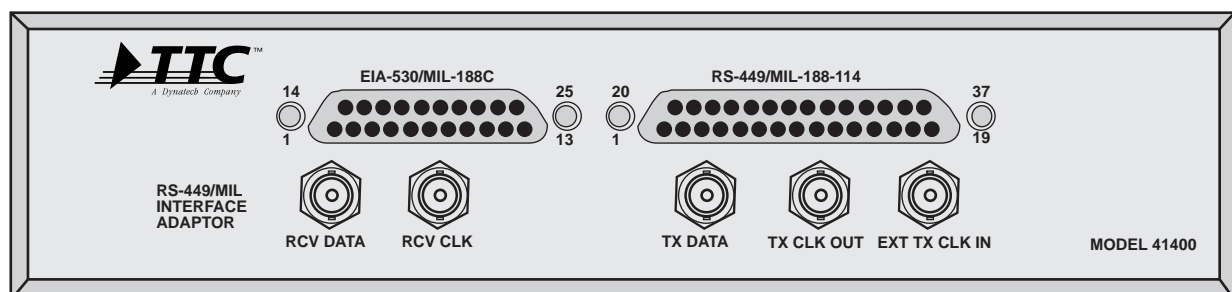

9500384-00

Figure 2-1  
The RS-449/530/MIL Data Interface

**Table 2-1**  
**RS-449/530/MIL INTERFACE PIN CONNECTIONS**

	25 Pin		Designations		EIA 530/188C Description	37 Pin		RS449 Circuit	449/MIL-188-114 Description	Status at Connectors	
	A	B	EIA	CCITT		A	B			DCE Mode	DTE Mode
	1 7		Shield AB	— 102	Shield Signal Ground	1 19 37 20		Shield SG SC RC	Shield Signal Ground Send Common Receive Common	Connected to chassis ground Connected to chassis ground Ground	Ground
	2 3	14 <sup>1</sup> 16 <sup>2</sup>	BA BB	103 104	Transmitted Data Received Data	4 6	22 <sup>1</sup> 24 <sup>2</sup>	SD RD	Send Data Receive Data	Input Output	Output Input
	4 5 6 20 8	19 <sup>1</sup> 13 <sup>2</sup> 22 <sup>2</sup> 23 <sup>2</sup> 10 <sup>2</sup>	CA CB CC CD CF	105 106 107 108.2 109	Request to Send Clear to Send DCE Ready DTE Ready Received Line Signal Detector	7 9 11 12 13	25 <sup>1</sup> 27 <sup>2</sup> 29 <sup>2</sup> 30 <sup>2</sup> 31 <sup>2</sup>	RS CS DM TR RR	Request to Send Clear to Send Data Mode Terminal Ready Receiver Ready	Input Output Output Output Output	Output Input Input Input Input
	24 15 17	11 <sup>1</sup> 12 <sup>2</sup> 9 <sup>1</sup>	DA DB DD	113 114 115	Transmit Signal Element Timing (DTE) Transmit Signal Element Timing (DCE) Receiver Signal	17 5 8	35 <sup>1</sup> 23 <sup>2</sup> 26 <sup>1</sup>	TT ST RT	Terminal Timing Send Timing Receive Timing	Input Output Output	Output Input Input
	18 21 25		LL RL TM	141 140 142	Local Loopback Remote Loopback Test Mode	10 14 18		LL RL TM	Local Loopback Remote Loopback Test Mode	Input Input Output	Output Output Input

**Table 2-2  
Twinax Connector References**

	<b>Circuit</b>	<b>Bal Pins</b>		<b>Unbal Pins</b>
RCV DATA	RD	6	24	6
RCV CLK	RT	8	26	8
TX DATA	SD	4	22	4
TX CLK OUT	TT	17	35	17
EXT CLK IN	ST	5	23	5

\* Referenced to the RS-449, Recommendation

### **2.2.1 General Characteristics**

The RS-449/530/MIL Data Interface, Model 41400, has the following dimensions and weight:

Height: 1.5" (38.0 mm)

Width: 7.5" (185.0 mm)

Depth: 5.23" (133.0 mm)

Weight: 13.6 ounces (386 grams)

### **2.2.2 Equipment and Items Included**

There is no equipment required to install the RS-449/530/MIL Data Interface, Model 41400. The RS-449/530/MIL Data Interface, Model 41400, is simply installed into the FIREBERD with thumb screws. Refer to paragraph 5.2 for installation instructions. No other equipment is necessary or provided. No other items are included with the RS-449/530/MIL Data Interface, Model 41400, other than this Operating Manual.

### **2.2.3 Tools and Equipment Required for Periodic Maintenance**

There are no tools or equipment required for periodic maintenance. Periodic maintenance consists of cleaning the RS-449/530/MIL Data Interface, Model 41400's exterior with a clean, lint free cloth. Cleaning sprays should not be used directly on the interface. Contacts should require little or no periodic maintenance. Contacts may be cleaned with a clean lint-free cloth. Contacts should not be cleaned with an abrasive cleaner.

### **2.2.4 Equipment Storage**

The RS-449/530/MIL Data Interface, Model 41400, should be stored in the original shipping container when not in use. Both the FIREBERD and the RS-449/530/MIL Data Interface, Model 41400, should be stored in a moisture and vibration free environment.

### **2.2.5 Unpacking, Assembly, and Installation Instructions**

The package containing the RS-449/530/MIL Data Interface, Model 41400, should be carefully checked for exterior damage. If no damage is apparent, the package should be opened carefully so that the RS-449/530/MIL Data Interface, Model 41400, is not damaged with a cutting blade or other sharp object. The RS-449/530/MIL Data Interface, Model 41400, should be checked against the bill of materials (BOM) to make sure that everything matches. Check the RS-449/530/MIL Data Interface, Model 41400, for any apparent exterior damage. Report any damage to the carrier and to TTC. Refer to warranty and return information in Chapter 8 of this manual.

Assembly of the RS-449/530/MIL Data Interface, Model 41400, is not required. The unit comes completely assembled. The interface itself, is the lowest replaceable unit (LRU). Installation procedures are provided in Section(s) 3 and 5 of this manual.

## **2.3 FUNCTIONAL DESCRIPTION**

The RS-449/530/MIL Data Interface, Model 41400, gives the FIREBERD 6000 DCE and DTE emulation capabilities. The RS-449/530/MIL Data Interface, Model 41400, has 25-pin D-type and 37-pin D-type or twinax connectors. In addition, the RS-449/530/MIL Data Interface, Model 41400, is capable of operating in either a balanced or unbalanced mode. Control of the RS-449/530/MIL Data Interface, Model 41400, is via the FIREBERD 6000 front panel interface setup menu or by remote control. The RS-449/530/MIL Data Interface, Model 41400, is capable of receiving data and clock inputs from a wide variety of data sources. It also has data and clock outputs for testing purposes. Internal circuitry consists of an internal clock generator, pattern generator, and receiver. This circuitry allows for a wide variety of testing capabilities. A six-position DIP switch allows for the selection of the ground termination. Paragraph 2.3.6 contains additional DIP switch details.

The RS-449/530/MIL Data Interface provides the FIREBERD Communications Analyzer with the ability to test and analyze RS-449, MIL-188-114, EIA-530, and MIL-188C compatible circuits using either the 25-pin, 37-pin, or twinax connectors. The following information provides a functional description of each TYPE of interface operation. For more information on TYPE selection, see Section 3.

### **2.3.1 RS-449**

When TYPE RS449 is selected, the RS-449/530/MIL Interface operates in accordance with EIA RS-449, CCITT V.10 and V.11, and ISO 4902-1980. TYPE RS449 enables a FIREBERD to act as data terminal equipment (DTE) or data communications equipment (DCE) when D-type connector is selected. Connections are made using a 37-pin D-type connector or twinax connector. Operation is possible in balanced or unbalanced mode. Balanced mode indicates that each signal is transmitted on two leads in which the voltage is equal in magnitude and opposite in polarity with respect to a common reference. This mode is preferred when minimum noise and cross talk is desired. Unbalanced mode indicates that each signal is transmitted on one lead with respect to a common ground. Data transmission is supported in synchronous or asynchronous timing. With asynchronous timing, asynchronous data analysis can be performed at speeds up to 20 kb/s. With synchronous timing, operation at 15 Mb/s is possible.

### **2.3.2 MIL-188-114**

When TYPE 188114 is selected, the RS-449/530/MIL Interface operates in accordance with the MIL-STD-188-114 Bipolar Balanced and Unbalanced Interface Specification, dated March 1976. TYPE 188114 enables a FIREBERD to act as data terminal equipment (DTE) or data communications equipment (DCE). Connections are made using a 37-pin D-type connector with operation possible in balanced or unbalanced mode. Balance mode indicates that each signal is transmitted on two leads in which the voltage is equal in magnitude and opposite in polarity with respect to a common reference. This mode is preferred when minimum noise and cross talk is desired. Unbalanced mode indicates that each signal is transmitted on one lead with respect to a common ground. Data transmission is supported in synchronous or asynchronous timing. With asynchronous timing, asynchronous data analysis can be performed at speeds up to 20 kb/s. With synchronous timing, operation at 15 Mb/s is possible.

### **2.3.3 EIA-530**

When TYPE EIA530 is selected, the RS-449/530/MIL Interface operates in accordance with EIA 530 specifications.

TYPE EIA530 enables a FIREBERD to act as data terminal equipment (DTE) or data communications equipment (DCE). Connections are made using a 25-pin D-type connector. Operation is possible in balanced or unbalanced mode. Balanced mode indicates that each signal is transmitted on two leads in which the voltage is equal in magnitude and opposite in polarity with respect to a common reference. This mode is preferred when minimum noise and cross talk is desired. Unbalanced mode indicates that each signal is transmitted on one lead with respect to a common ground. Data transmission is supported in synchronous or asynchronous timing. With asynchronous timing, asynchronous data analysis can be performed at speeds up to 20 kb/s. With synchronous timing, operation at 15 Mb/s is possible.

### **2.3.4 MIL-188C**

When TYPE 188C is selected, the RS-449/530/MIL Interface operates in accordance with the MIL-STD-188C Interface specification. This interface enables the FIREBERD to act as data terminal equipment (DTE) or data communications equipment (DCE). Connections are made using a 25-pin D-type connector. Operation is in unbalanced mode. Unbalanced mode indicates that each signal is transmitted on one lead with respect to a common ground. Data transmission is supported in synchronous or asynchronous timing. With asynchronous timing, asynchronous data analysis can be performed at speeds up to 20 kb/s. With synchronous timing, operation at 64 kb/s is possible.

### **2.3.5 Twinax Connectors**

The five twinax connectors RCV DATA, RCV CLK, TX DATA, TX CLK OUT, and EXT TX CLK IN enables the FIREBERD to test a wide variety of data handling devices. The connectors enable operation in balanced and unbalanced mode with the connector shields connected to chassis ground, the middle conductor carrying the Category II (B) signal, and the center carrying the Category I (A) signal. Balanced mode indicates that each signal is transmitted on two leads (A & B) in which the voltage is equal in magnitude and opposite in polarity with respect to a common reference. This mode is preferred when minimum noise and cross talk is desired. Unbalanced mode indicates that each signal is transmitted on one lead (A) with respect to a common ground. Data transmission is supported in synchronous or asynchronous timing. With asynchronous timing, asynchronous data analysis can be performed at speeds up to 20 kb/s. With synchronous timing, operation at 15 Mb/s is possible. Data generated by the FIREBERD is transmitted through the TX DATA jack. The synchronous transmitted clock signal is sent through the TX CLK OUT jack. Data is returned to the FIREBERD for analysis through the RCV DATA jack. The synchronous returned clock is sent through the RCV CLK

jack. A clock signal via the EXT TX CLK IN jack may be selected as the timing source for the transmitted data signal.

### 2.3.6 DIP Switch

Use DIP switch position 3, 4, and 5 to reduce the amplitude noise level on the EXT TX CLK IN, RCV CLK, and RCV DATA leads by changing the line to line termination to line to ground termination. The 124 ohm line to line termination of the external transmit clock input, receive clock, and receive data may be split by placing a 62 ohm resistor from each line to ground. Figure 2-2 illustrates the factory settings for the DIP switches.

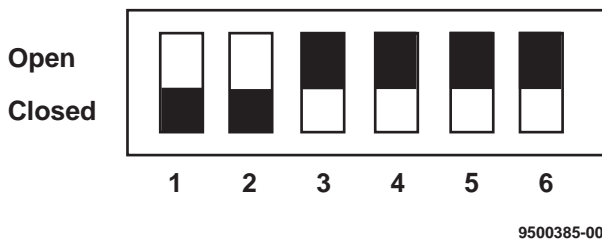

**Figure 2-2**  
**DIP Switch Factory Settings**

**Position 1 and Position 2 are not used.**

**Position 3 External Tx Clock Input** - This switch allows the center of the two EXT TX CLK IN 62 ohm resistors to be connected to ground. In the normal (OPEN) position the two 62 ohm resistors are not terminated to ground allowing line to line termination. In the opposite (CLOSED) position the center of the resistors are terminated to ground allowing line to ground termination.

**Position 4 Receive Clock** - This switch allows the center of the two RCV CLK 62 ohm resistors to be connected to ground. In the normal (OPEN) position the two 62 ohm resistors are not terminated to ground allowing line to line termination. In the opposite (CLOSED) position the center of the resistors are terminated to ground allowing line to ground termination.

**Position 5 Receive Data** - This switch allows the center of the two RCV DATA 62 ohm resistors to be connected to ground. In the normal (OPEN) position the two 62 ohm

resistors are not terminated to ground allowing line to line termination. In the opposite (CLOSED) position the center of the resistors are terminated to ground allowing line to ground termination.

## 2.4 MAINFRAME OPERATION WITH THE RS-449/530/MIL INTERFACE

### 2.4.1 Emulating Synchronous DTE

The FIREBERD mainframe generator clock and pattern selections must be configured for operation with the RS-449/530/MIL Interface. Figure 2-3 illustrates a simplified block diagram of the FIREBERD emulating synchronous DTE. The diagram shows the relationship between the generator clock, test pattern generator, receiver, and RS-449/530/MIL Interface transmit and receive data and clock leads. Two sets of pin numbers are identified: the EIA-530/MIL-188C connector and the RS-449/MIL 188-114 which is in parenthesis. See Table 2-1 for pin out descriptions.

**NOTE:** Only Category I circuits are identified. See Table 2-1 for corresponding Category II circuits.

The generator clock selection establishes which clock source is used during testing: the internal (INTRNL), interface (INTF), or external (BNC). When the generator clock is set to INTRNL, the mainframe supplies the clock source from the internal generator clock which is used to generate the test pattern on Pin 2 Transmitted Data (Pin 4 Send Data) and supply the external transmit clock on Pin 24 Transmit Clock DTE source (Pin 17 Terminal Timing DTE source). The DCE transmit clock on Pin 15 Transmit Clock DCE source (Pin 5 Send Timing DCE source) is ignored when the internal mainframe clock is used.

With the generator clock set to INTF, the clock on Pin 15 (Pin 5) is used as the transmit timing source for transmitting the test pattern on Pin 2 (Pin 4). It also supplies the external transmit clock on Pin 24 (Pin 17). Typically, the DCE supplies transmit timing to the DTE on Pin 15 (Pin 5) and the DTE (FIREBERD) generates the data (test pattern) from that clock and redistributes the timing signal on Pin 24 (Pin 17) to the DCE. Setting the generator clock for INTF is the recommended selection when the FIREBERD is emulating DTE.

With the generator clock set for BNC, the mainframe is supplied with the clock source through the GEN CLK IN connector on the rear panel. The received data is clocked in on Pin 3 Received Data (Pin 6 Receive Data) with the receive clock from the DCE on Pin 17 Receive Clock (Pin 8 Receive Timing) supplying the timing. Signal analysis is performed on the received data and receive clock signals.

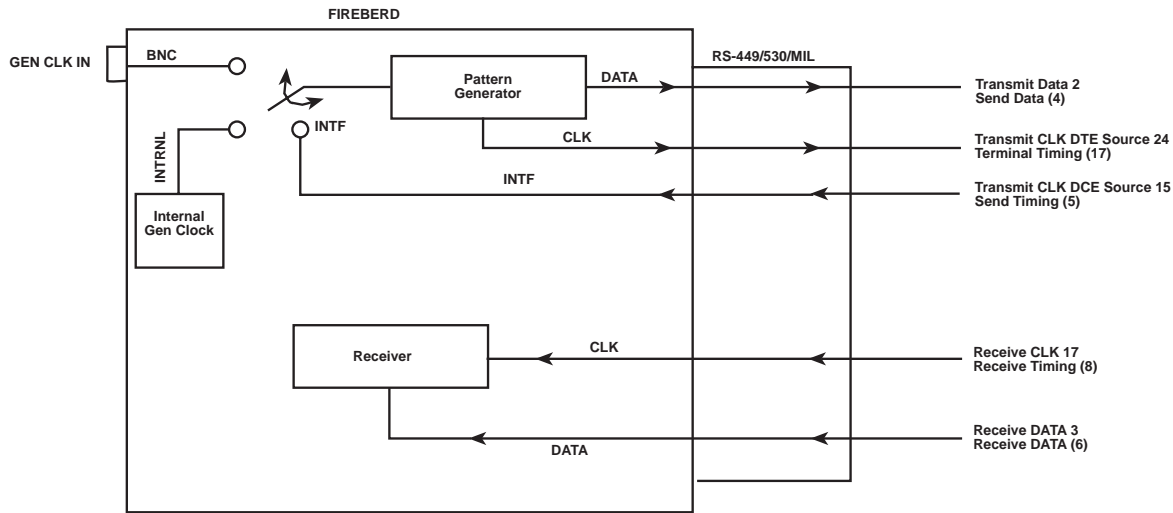

**KEY**  
 EIA 530/188C Reference  
 RS-449/MIL-188-114 Reference

9500386-00

**Figure 2-3  
 FIREBERD Emulating Synchronous DTE**

Set the pattern selection to any test pattern, except FOX and USER 1-3. If the Long User Option is installed these patterns may be selected.

During DTE emulation, the Interface Status and Control panel switches control RTS (Request To Send) and DTR (Data Terminal Ready) by turning the leads off and on. The status of RLSD (Received Line Signal Detector), DSR (Data Set Ready), TM (Test Mode), and CTS (Clear To Send) is monitored and displayed on the front panel.

#### **2.4.2 Operating as Synchronous DCE**

The FIREBERD mainframe generator clock and pattern selections must be configured for operation with the RS-449/530/MIL Interface. Figure 2-4 illustrates a simplified block diagram of the FIREBERD 4000 emulating synchronous DCE. The diagram shows the relationship between the generator clock, test pattern generator, receiver, and RS-449/530/MIL Interface transmit and receive data and clock leads. Two sets of pin numbers are identified: the EIA-530/MIL-188C connector and the RS-449/MIL 188-114 which is in parenthesis. See Table 2-1 for pin out descriptions.

During DCE emulation, the Interface Status and Control panel switches control RLSD (Received Line Signal Detector) and DSR (Data Set Ready) by turning the leads off and on. The status of RTS (Request to Send), LL (Local Loopback), RL (Remote Loopback), and DTR (Data Terminal Ready) is monitored and displayed on the front panel. TM (Test Mode) and CTS (Clear to Send) are controlled using the Signaling Menu.

#### **2.4.3 Emulating Asynchronous DTE/DCE**

When selecting asynchronous DTE/DCE operation the data bits (5, 6, 7, or 8), parity (EVEN, ODD, NONE), and the stop bits (1, 1.5, or 2) need to match the parameters of the equipment being tested. The FIREBERD can emulate asynchronous DTE/DCE and operate from 50 kb/s to 20 kb/s. Set the generator clock to INTERNAL and select the appropriate clock frequency to match the required data rate. Do not use the BNC selections when operating asynchronously.

The following patterns are valid in asynchronous testing: MARK, SPACE, 1:1, 63, 511, 2047,  $2^{15}-1$ , FOX, and USER

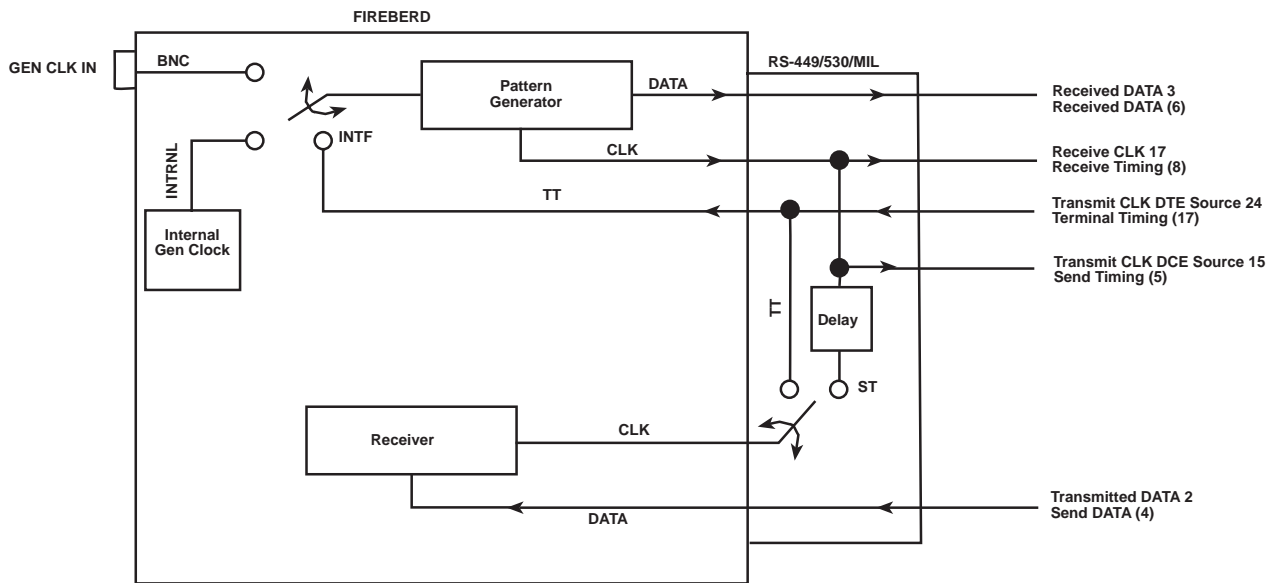

**KEY**  
 EIA 530/188C Reference  
 RS-449/MIL-188-114 Reference

9500387-00

**Figure 2-4**  
**FIREBERD Emulating Synchronous DCE**

1-3. If any other pattern is selected, ASYNC PATTERN CONTENTION flashes in the ANALYSIS RESULTS display.

During DCE emulation, the Interface Status and Control panel switches control RLSD (Received Line Signal Detector) and DSR (Data Set Ready) by turning the leads off and on. RL (Remote Loopback) and LL (Local Loopback) are controlled using the Signaling Menu. The status of RTS (Request to Send), LL (Local Loopback), RL (Remote Loopback), and DTR (Data Terminal Ready) is monitored and displayed on the front panel. During DTE emulation, the Interface status and Control panel switches control RTS (Request To Send) and DTR (Data Terminal Ready) by turning the leads off and on. The status of RLSD (Received Line Signal Detector), DSR (Data Set Ready), TM (Test Mode), and CTS (Clear To Send) is monitored and displayed on the front panel.

#### 2.4.4 Operating in the Self-Loop Mode

In DTE emulation, the self-loop mode loops the TD lead Pin 2 (Pin 4) to the RD lead Pin 3 (Pin 6) and the XTC lead Pin 24 (Pin 17) to the RC lead Pin 17 (Pin 8). Timing can be

provided by the DCE on Pin 15 (Pin 5) [generator clock set to INTF], the internal generator clock [generator clock set to INTRNL], or the rear panel GEN CLK IN connection [generator clock set to BNC].

In DCE emulation, the self-loop mode loops the RD lead Pin 3 (Pin 6) to the TD lead Pin 2 (Pin 4) and the RC lead Pin 17 (Pin 8) to the XTC lead Pin 24 (Pin 17). Timing can be provided by the internal generator clock (generator clock set to INTRNL) or the rear panel GEN CLK IN connection (generator clock set to BNC). User connections do not have to be disconnected to perform the self-loop test.





## FIREBERD 4000 INSTALLATION AND OPERATION

### 3.1 INTRODUCTION

This section describes how to install, configure, and operate the RS-449/530/MIL Data Interface with a FIREBERD 4000. Refer to the *FIREBERD 4000 User's Guide* or the *FIREBERD 4000 Reference Manual* for mainframe operating procedures.

**NOTE:** Configure the FIREBERD 4000 and the RS-449/530/MIL Data Interface before connecting the FIREBERD to the circuit under test. This avoids unnecessary circuit downtime.

#### 3.1.1 Repair and Replace Procedure

The RS-449/530/MIL Data Interface, Model 41400, is provided as a self-contained unit. If repairs are necessary, the entire interface should be replaced. Section 8 of this manual contains information about the warranty and return policies.

### 3.2 INSTALLING THE INTERFACE

The following procedure describes how to install the RS-449/530/MIL Interface in the FIREBERD 4000. Figure 3-1 illustrates how the interface is installed.

**CAUTION:** Before installing or removing the interface module, turn the AC power OFF to the FIREBERD mainframe. Damage can occur to the interface and mainframe.

1. Power OFF the FIREBERD.
2. Face the FIREBERD rear panel.

**NOTE:** The FIREBERD 4000 may have two interface slots. SLOT1 (bottom slot) is the standard interface slot and SLOT2 (top slot) is the optional interface slot (Option 4001).

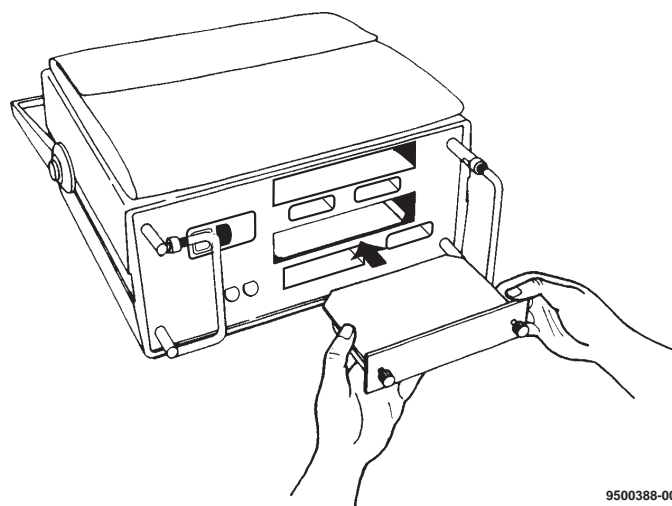

**Figure 3-1**  
**Installing a Modular Interface**

3. Insert the interface into a vacant interface slot. Verify that the interface faces up.
4. Slide the module into the FIREBERD until the interface panel is flush with the rear panel. Make sure the PC board edges are fitted into the card guides inside the interface slot.
5. Secure the interface with the two thumbscrews on the interface panel.

### 3.2.1 Performance Verification

The proper performance of the RS-449/530/MIL Data Interface, Model 41400, is verified by installing the interface in the FIREBERD 4000 as described in the previous paragraphs. The FIREBERD 4000 should be setup as described in the step-by-step procedures in the following paragraphs. The equipment should be powered-up and the various menus and setups performed to ensure proper operation. If any test fails, be sure to check connections, continuity of cables, and proper seating of the interface into the FIREBERD. An analysis of test results and proper performance indicators are provided in the analysis results section at the back of this section. In addition, the *FIREBERD 4000 Reference Manual* provides additional performance verification and validation results.

### 3.2.2 Calibration Procedures

The RS-449/530/MIL Data Interface, Model 41400, is factory checked and requires no calibration. The FIREBERD 4000 is calibrated as described in the *FIREBERD 4000 Reference Manual*.

### 3.2.3 Parts List and Vendors List

No parts list or vendors list is provided because the RS-449/530/MIL Data Interface, Model 41400, is the LRU. See Section 8 of this manual for replacement and warranty information.

## 3.3 FIREBERD 4000 INTERFACE SET-UP

This section describes how to access the interface menu and discusses each of the menu selections in the RS-449/530/MIL Data Interface menu.

The RS-449/530/MIL Data Interface is controlled through the FIREBERD 4000 INTERFACE SETUP category. Press the MIL449 softkey to access the MIL449 interface menu.

Use the SETUP SELECT switch to step through the menus. Press the softkeys to select a function as indicated by the softkey labels on the bottom line of the display. To return to the interface select menu, press the mainframe HOME key. All interface menu settings are retained when power is removed from the mainframe. See Figures 3-2 through 3-7 for the interface menus.

### 3.3.1 Operating Type Menu

The Operating Type (TYPE) menu allows the user to select either 188114, RS449, EIA530, or 188C as the type of interface operation. Press the appropriate softkey to select the desired operating type. Press the MORE key to display the 188C softkey label. Modifying TYPE will cause a test restart.

**188114** - The 188114 operating type configures the interface to be connected to a MIL-188-114 compatible circuit.

**RS449** - The RS449 operating type configures the interface to be connected to a RS-449 compatible circuit.

**EIA530** - The EIA530 operating type configures the interface to be connected to a EIA-530 compatible circuit.

**188C** - The 188C operating type configures the interface to be connected to a MIL-188C compatible circuit.

### 3.3.2 Connector Menu

The connector (CONNECTOR) menu only appears when TYPE 188114 or TYPE RS449 is selected. This menu controls the type of data interface which the FIREBERD can be connected to. Modifying CONNECTOR will causes a test restart. Pressing the associated softkey selects either D-TYPE or TWINAX.

**D-TYPE** - When the D-TYPE softkey is pressed, the interface is configured to use the RS-449/MIL188-114, 37-pin connector.

**TWINAX** - When the TWINAX softkey is pressed, the interface is configured to use the twinax connectors.

### 3.3.3 Emulate Menu

The Emulate (EMULATE) menu establishes the interface emulation mode. Pressing the associated softkey selects either DTE or DCE emulation. This menu does not appear when the selected CONNECTOR is TWINAX.

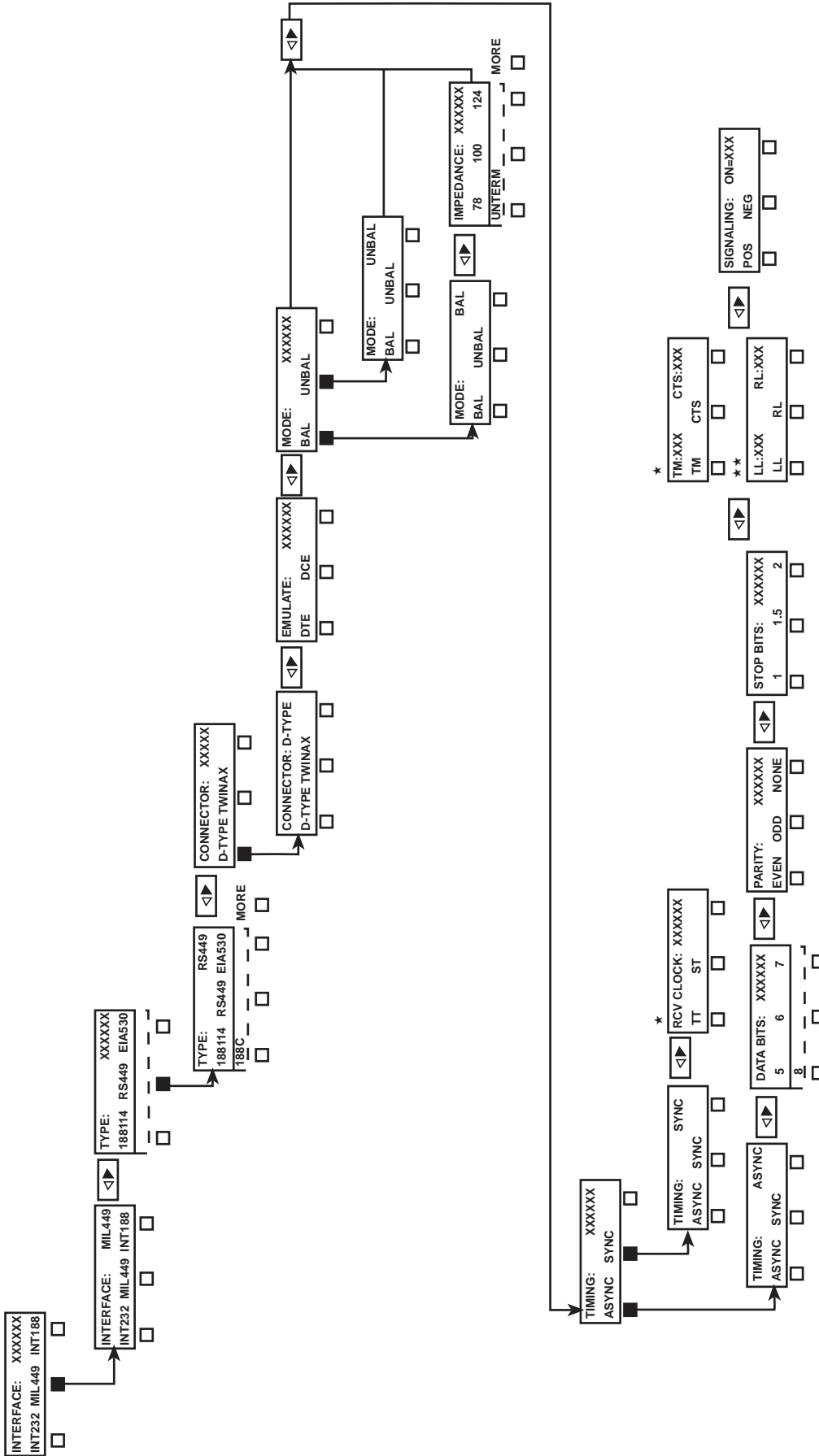

9500389-00

\* EMULATE DCE  
\*\* EMULATE DTE

Figure 3-2  
FIREBERD 4000 RS-449/530/MIL Data Interface Setup Menu  
Type RS-449 D-Type

INTERFACE: XXXXXX  
INT232 MIL449 INT188

INTERFACE: MIL449  
INT232 MIL449 INT188

TYPE: XXXXXX  
188114 RS449 EIA530  
188C

CONNECTOR: XXXXXX  
D-TYPE TWINAX

CONNECTOR: TWINAX  
D-TYPE TWINAX

MODE: XXXXXX  
BAL UNBAL

MODE: BAL UNBAL

MODE: BAL UNBAL

IMPEDANCE: XXXXXX  
78 100 124  
TUNTERM

MORE

TIMING: XXXXXX  
ASYNC SYNC

\* RCV CLOCK: XXXXXX  
TT ST

TIMING: ASYNC SYNC

DATA BITS: XXXXXX  
5 6 7

PARITY: XXXXXX  
EVEN ODD NONE

STOP BITS: XXXXXX  
1 1.5 2

\* EMULATE DCE

9500390-00

Figure 3-3  
FIREBERD 4000 RS-449/530/MIL Data Interface Setup Menu  
Type RS-449 Twinax

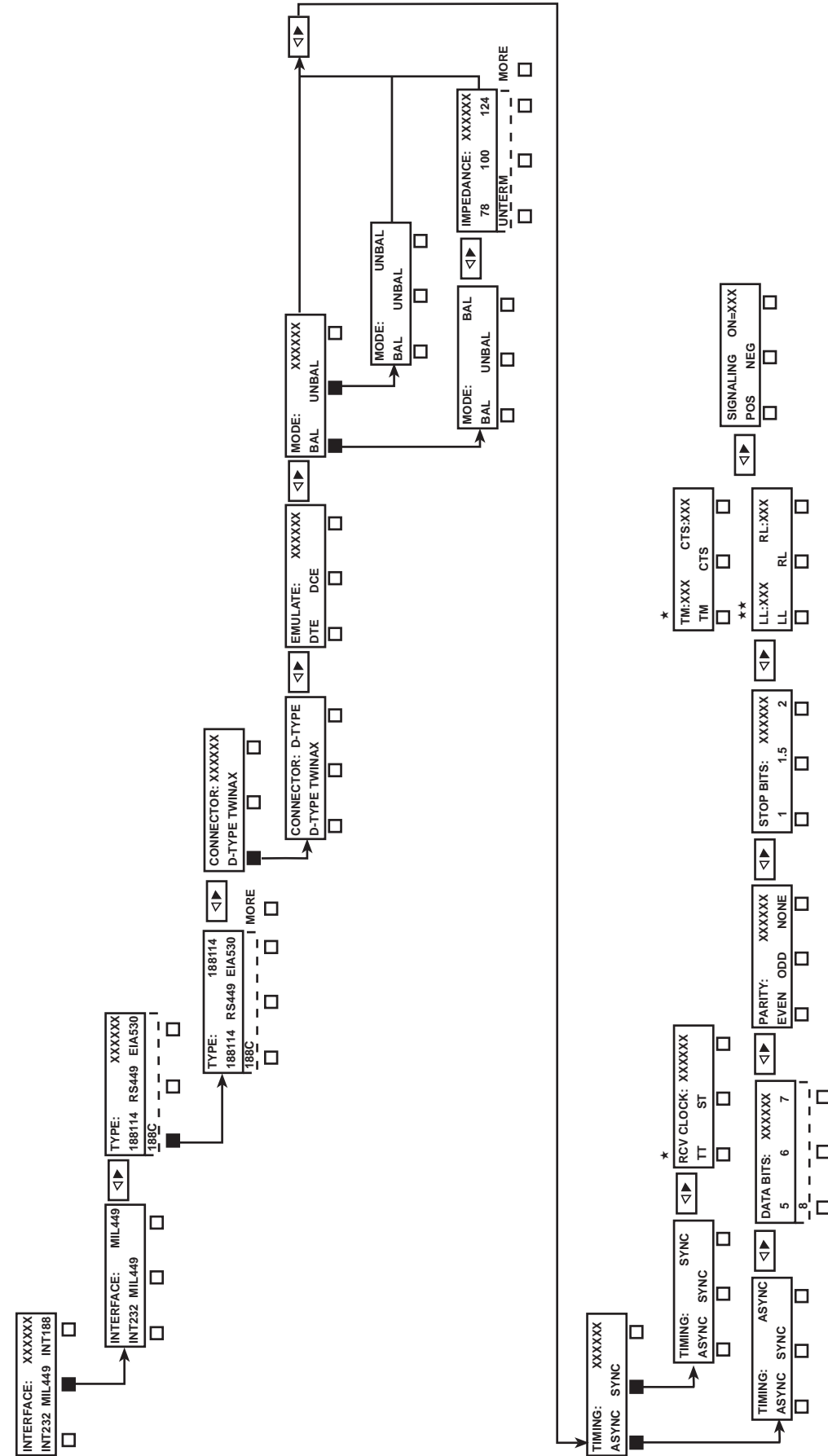

\* EMULATE DCE  
 \*\* EMULATE DTE

9500391-00

Figure 3-4  
 FIREBERD 4000 RS-449/530/MIL Data Interface Setup Menu  
 Type 188/114 D-Type

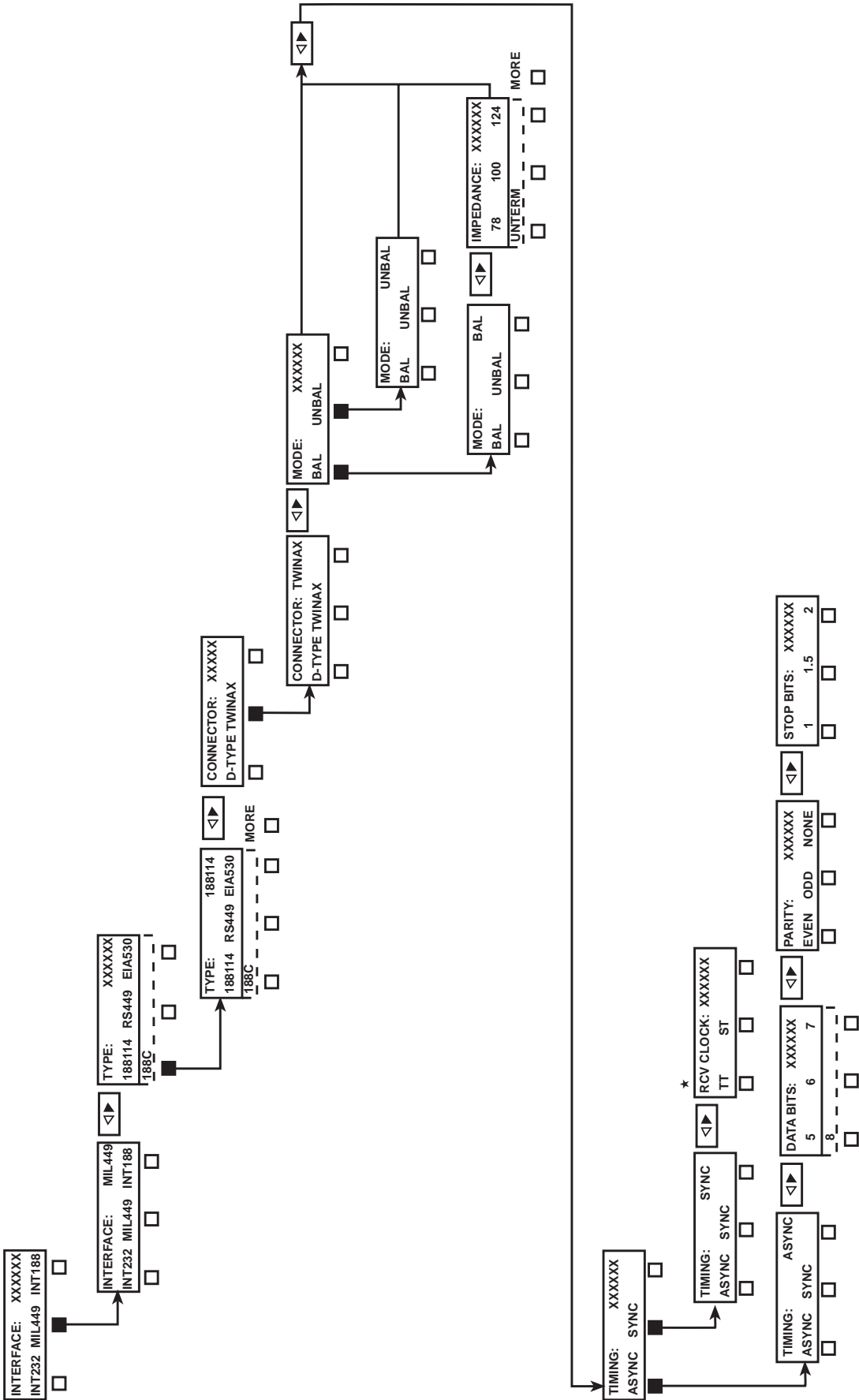

9500392-00

\* EMULATE DCE

Figure 3-5  
**FIREBERD 4000 RS-449/530/MIL Data Interface Setup Menu**  
 Type 188/114 Twinax

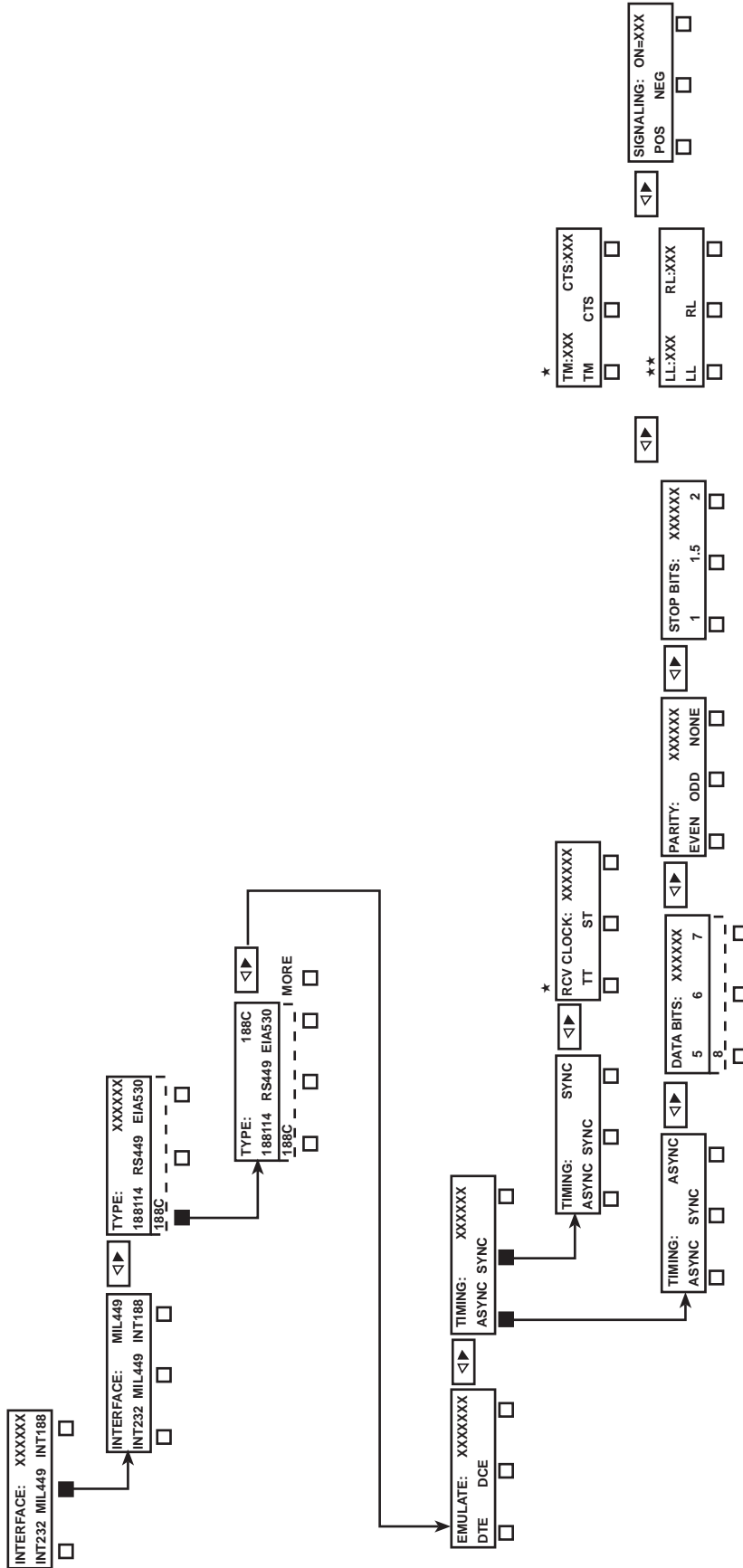

\* EMULATE DCE  
 \*\* EMULATE DTE

9500393-00

Figure 3-6  
 FIREBERD 4000 RS-449/530/MIL Data Interface Setup Menu  
 Type 188C

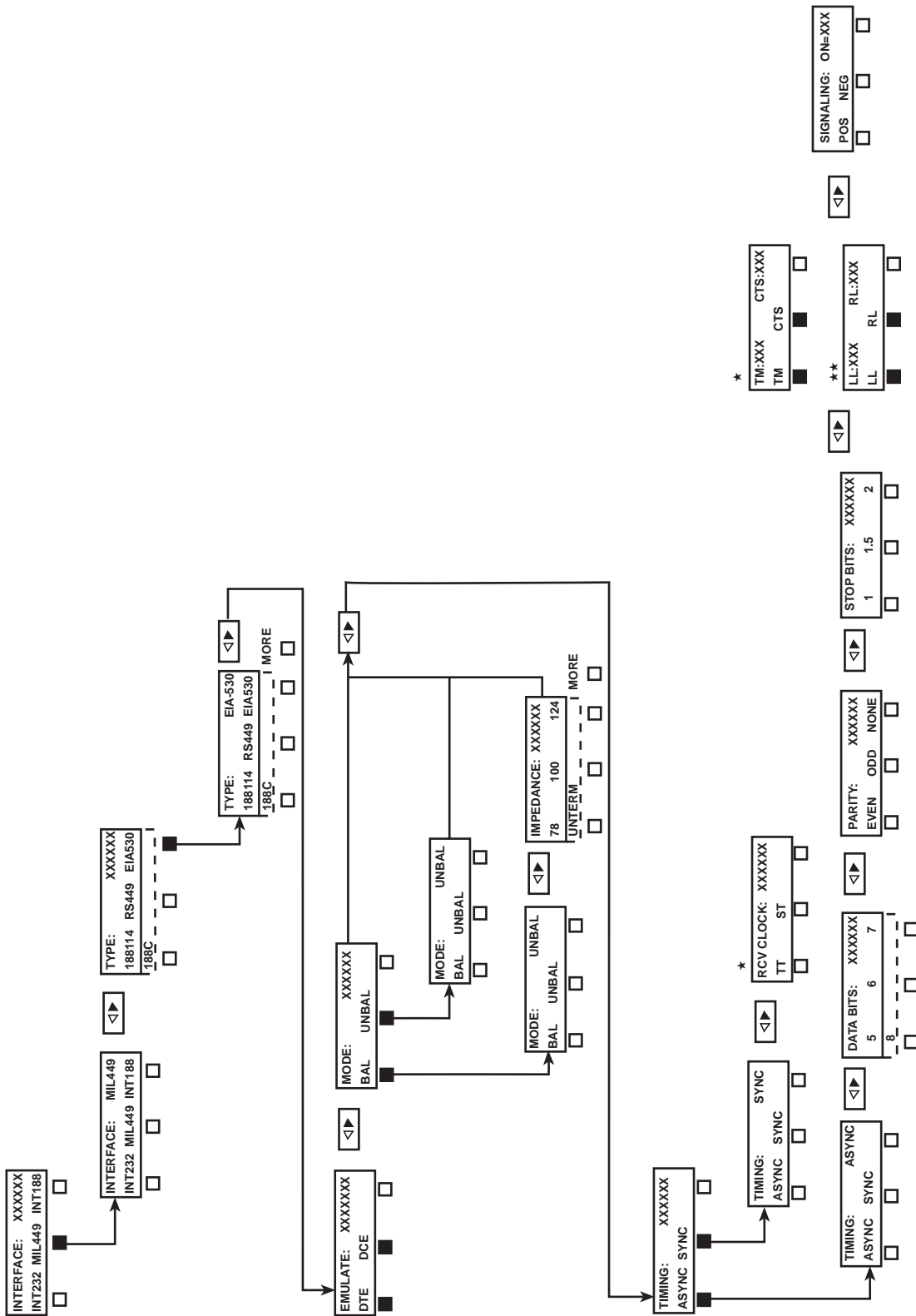

\* EMULATE DCE  
\*\* EMULATE DTE

9500394-00

Figure 3-7  
FIREBERD 4000 RS-449/530/MIL Data Interface Setup Menu  
Type EIA530



**DTE** - This selection allows the FIREBERD mainframe to emulate DTE.

**DCE** - This selection allows the FIREBERD mainframe to emulate DCE.

### 3.3.4 Mode Menu

The Mode (MODE) menu allows the user to select between balanced and unbalanced operation. Modifying MODE causes a test restart.

**BAL** - This selection allows the FIREBERD to operate in a balanced mode. Balanced mode indicates that each signal is transmitted on two leads in which the voltage is equal in magnitude and opposite in polarity with respect to a common reference. This mode is preferred when minimum noise and cross talk is desired. When balanced mode is selected the following menu is provided to set the termination impedance. The termination impedance should be set to match the characteristics of the cable.

**IMPEDANCE** - This menu allows you to select either a termination impedance of 78 ohms, 100 ohms, 124 ohms, or UNTERM (>7.4 k ohms).

**UNBAL** - This selection allows the FIREBERD to operate in an unbalanced mode. In unbalanced mode each signal is transmitted on one lead with respect to a common ground.

### 3.3.5 Timing Menu

The Timing (TIMING) menu establishes the mainframe timing mode. Pressing the associated softkey selects either asynchronous (ASYNC) or synchronous (SYNC) timing. Modifying TIMING will cause a test restart.

**ASYNC** - This softkey selects the asynchronous timing mode. Asynchronous timing is limited to data rates up to 20 kb/s. The following PATTERNS are valid in asynchronous testing: MARK, SPACE, 1:1, 63, 511, 2047, 2<sup>15</sup>-1, FOX, and USER 1-3. When using asynchronous timing, the following menus are provided to set the character length, parity, and stop bits. The selected parameters should be consistent with the parameters of the equipment being tested.

**DATA BITS: 5|6|7|8** - This menu determines the number of bits used to create the data byte format. The bit length can be 5, 6, 7, or 8 bits long. Press the associated softkey to select the appropriate bit length. Press the MORE key

to select the 8-bit format (default = 8). Modifying DATA BITS will cause a test restart.

**PARITY: EVEN|ODD|NONE** - This menu determines the orientation of the parity bit. Parity is a form of error detection used in asynchronous data. Press the associated softkey to select the appropriate parity: EVEN, ODD, or NONE. Selecting EVEN enables the parity bit when the number of ones in the data byte is an even number. Selecting ODD enables the parity bit when the number of ones in the data byte is an odd number. Select NONE when no parity bit is used (default = ODD). Modifying PARITY will cause a test restart.

**STOP BITS: 1|1.5|2** - This menu determines the number of stop bits required in the character format. Press the associated softkey to select the appropriate stop bit format: 1, 1.5, or 2 (default = 1). Modifying STOP BITS will cause a test restart.

**SYNC** - This selects the synchronous timing mode. With synchronous timing, operation to 15 Mb/s is possible (default = SYNC).

**RCV CLOCK** - This menu only appears when the mainframe is emulating synchronous DCE using a D-Type connector. This menu selects the timing reference that the mainframe is synchronized to: TT (Terminal Timing), or ST (Send Timing). When TT is selected, the receiver timing source comes from Pin 24 (EIA530/MIL188C) or Pin 17 (RS-449/MIL188-114). When ST is selected, the receiver timing source is the mainframe generator clock that is sent out on Pin 15 (EIA530/MIL188C) or Pin 5 (RS-449/MIL188-114).

### 3.3.6 Signaling Menu

**TM:OFF|ON CTS:OFF|ON** - This menu only appears when the mainframe is configured for D-TYPE CONNECTOR and DCE EMULATION. The operation of the TM (Test Mode) lead [Pin 25 (EIA530/MIL188C) or Pin 18 (RS-449/MIL188-114)] and the operation of the CTS (Clear to Send) lead [Pin 5 (EIA530/MIL188C) or Pin 9 (RS-449/MIL188-114)] are controlled by this menu. Press the TM softkey to toggle the TM lead ON and OFF. ON equals a logic HIGH. OFF equals a logic LOW. Press the CTS softkey to toggle the CTS lead ON and OFF. ON equals a logic HIGH. OFF equals a logic LOW.

**LL:OFF|ON RL:OFF|ON** - This menu only appears when the mainframe is configured for D-TYPE CONNECTOR and DTE EMULATION. The operation of the LL (Local Loopback) lead [Pin 18 (EIA530/MIL188C) or Pin 10

(RS-449/MIL188-114)] and the operation of the RL (Remote Loopback) lead [Pin 21 (EIA530/MIL188C) or Pin 18 (RS-449/MIL188-114)] are controlled by this menu. Press the LL softkey to toggle the LL lead ON and OFF. ON equals a logic HIGH. OFF equals a logic LOW. Press the RL softkey to toggle the RL lead ON and OFF. ON equals a logic HIGH. OFF equals a logic LOW.

**SIGNALING:ON=POS|NEG** - This menu only appears when the D-TYPE CONNECTOR is selected. This menu controls the polarity of all the interface signaling control leads. Press the appropriate softkey to set ON equal to

POS (positive) or NEG (negative) polarity. Selecting ON=POS sets the ON condition to a positive value and an OFF condition to a negative value. Selecting ON=NEG sets the ON condition to a negative value and an OFF condition to a positive value.

### 3.4 FIREBERD 4000 ANALYSIS RESULTS

Table 3-1 lists the analysis results that are displayed when the RS-449/530/MIL Data Interface is installed in the FIREBERD 4000. Refer to the FIREBERD 4000 Reference Manual for results definitions.

**Table 3-1  
FIREBERD 4000 Analysis Results**

Category	Displayed Result	Description
ERROR	AVG BER	Average Bit Error Rate
	AVG BLER	Average Block Error Rate
	BER	Bit Error Rate
	BIT ERRS	Bit Errors
	BLK ERRS	Block Errors
	BLOCKS	Blocks
	CHAR ERR <sup>1</sup>	Character Errors
	PAT LOSS	Pattern Synchronization Loss
	PAT SLIP <sup>2</sup>	Pattern Slips
TIME & SIGNAL	%EFS	Percent of Error-Free Seconds
	DATE	Date
	DELAY <sup>4</sup>	RTS/CTS Delay
	ELAP SEC	Elapsed Seconds
	ERR SEC	Errored Seconds
	GEN FREQ	Generator Clock Frequency
	PATL SEC	Pattern Loss Seconds
	RCV FREQ <sup>3</sup>	Receiver Clock Frequency
	TEST SEC	Test Seconds
	TIME	Time
PERFORMANCE <sup>5</sup>	%AVL SEC	Percent of Available Seconds
	%DEG MIN	Percent of Degraded Minutes
	%SES	Percent of Severely Errored Seconds
	AVL SEC	Available Seconds
	DEG MIN	Degraded Minutes
	G %EFS	G.821 Percent of Error Free Seconds
	G EFS	G. 821 error Free Seconds
	GERR SEC	G.821 Errored Seconds
	SES	Severely Errored Seconds
	UNA SEC	Unavailable Seconds

<sup>1</sup>Asynchronization timing only

<sup>2</sup>Synchronous timing with pseudorandom patterns only

<sup>3</sup>Synchronous timing only

<sup>4</sup>DTE only

<sup>5</sup>Requires option 4004

### 3.5 FIREBERD 4000 SELF-LOOP TEST

The RS-449/530/MIL Data Interface includes a relay that is activated by the SELF LOOP pushbutton switch on the FIREBERD front panel. Pressing the SELFLOOP pushbutton connects the transmit clock and data to the receive clock and data. This provides quick verification of the FIREBERD and the data interface. User connections do not need to be removed during the test, since complete isolation is provided by the relay when testing in the Self-Loop mode.

### 3.6 INTERFACE STATUS INDICATORS AND SWITCHES

Depending on the EMULATE selection (DTE or DCE) the corresponding front panel interface status and control panel label will illuminate. The LEDs to the right of these labels indicate activity on the associated interface connector lines. The following describes what each LED indicates. The DTE and DCE emulation labels not in parentheses indicate EIA 530/MIL-188C lead notation and the labels in parentheses indicate RS-449/MIL188-114 lead notation.

#### Switches

**RLSD (RR)** - In DCE emulation the pushbutton switch controls the state of the Received Line Signal Detector line. Pressing the RLDS pushbutton causes it to illuminate, forcing this line ON. When the pushbutton LED is extinguished, the line is held OFF.

**DSR (DM)** - In DCE emulation, pressing the corresponding pushbutton illuminates the LED and forces the DSR line ON. Pressing this pushbutton again extinguishes the LED and the DSR line is held OFF.

**RTS** - In DTE emulation, pressing the Request To Send pushbutton illuminates the LED and forces this line ON. Pressing this pushbutton again extinguishes the LED and holds the line OFF.

**DTR** - In DTE emulation, pressing this pushbutton illuminates the LED and forces the Data Terminal Ready line ON.

#### Indicators

**RLSD** - In DTE emulation, the Received Line Signal Detector illuminates when this line is ON.

**DSR** - In DTE emulation, the Data Set Ready LED illuminates when this line is ON.

**CTS** - In DTE emulation, the Clear To Send LED illuminates when this line is ON. In DCE emulation, there is no corresponding LED.

**RTS** - In DCE emulation, the Request To Send LED illuminates when this line is ON.

**DTR** - In DCE emulation, the LED illuminates when this line is ON.

**TM** - In DTE emulation, the Test Mode LED illuminates when this line is ON. In DCE emulation, there is no corresponding LED.

**LL** - In DCE emulation, the Local Loopback LED illuminates when this line is ON. In DTE emulation, there is no corresponding LED.

**RL** - In DCE emulation, the Remote Loopback LED illuminates when this line is ON. In DTE emulation, there is no corresponding LED.

### 3.7 FIREBERD 4000 PRINTER OPERATION

Refer to the *FIREBERD 4000 Reference Manual* for printer setup and operating instructions. Figure 3-8 is a typical Controls printout showing a RS-449/530/MIL Data Interface. Figure 3-9 shows a typical Results printout with the RS-449/530/MIL Data Interface.

**NOTE:** Only the interface setting relevant to the current interface mode are displayed.

```

CONTROLS PRINT      14:27:19  24 JUL 90
PATTERN            QRSS  ERROR INSERT  OFF
SELF LOOP          OFF   GEN CLOCK   SYNTH
SYN FRQ 1544.0 kHz DISPLAY HOLD  OFF
SETUP PROGRAM NO.0
AUXILIARY SETUP
FLOW TR/DTR        OFF   FLOW DM/DSR  OFF
FLOW RS/RTS        OFF   FLOW CS/CTS  OFF
FLOW RRS/RLSD      OFF   SYN LOS ACT  HALT
SYN LOS THR NORMAL USER SYN THR  10
BLOCK LENGTH PATT  PRINT FMT  STANDARD
STATUS PRINTS      OFF   PRINT EVENT  AUX ER
BIT ERROR          OFF   BLOCK ERROR  OFF
BPV ERROR          OFF   CODE ERROR   OFF
FRAME ERROR        OFF   FRA WORD ERR OFF
CRC ERROR          OFF   PATTERN SLIP OFF
INTERFACE SLOT 2   RS449/530/MIL
TYPE               RS449  CONNECTOR    D-TYPE
EMULATE           DTE    MODE         BAL
IMPEDANCE         100    TIMING       ASYNC
LL                OFF    RL          OFF
DTR               ON     RTS         ON
SIG POLAR POSITIVE

```

**Figure 3-8  
Controls Printout**

```

MANUAL PRINT      14:29:26  24 JUL 90
BIT ERRS          AVG BER
BER              PAT SLIP
BLK ERRS         BLOCKS
AVG BLER         PAT LOSS
PATL SEC         ERR SEC
%EFS             TEST SEC           1
ELAP SEC         129  GEN FREQ       1543488
RCV FREQ         0.0  DELAY
AVL SEC          UNA SEC
%AVL SEC         DEG MIN
%DEG MIN         G EFS
GERR SEC         G %EFS
SES              %SES
RR               OFF  DM             OFF
CS               OFF  TM             OFF
RS               ON   TR             ON
IF  RS449/530/MIL

```

**Figure 3-9  
Long Results Printout**

### 3.8 FIREBERD 4000 REMOTE CONTROL COMMANDS

The FIREBERD 4000 remote control commands enable remote control over the RS-449/530/MIL Data Interface. The RS-449/530/MIL Data Interface commands are listed in Table

3-2. The spacing used on each command line must be used as indicated. Table 3-2 defines the remote control commands abbreviations. For detailed instructions on remotely controlling the FIREBERD 4000, refer to the *FIREBERD 4000 Reference Manual*.

**Table 3-2**  
**RS-449/530/MIL Data Interface FIREBERD 4000 Remote Control Commands**

Remote Command	Result
INT SET MIL449 TYP INT SET MIL449 TYP (xxxxxx)	Prints current interface type setup Selects the interface type (xxxxxx = 188114, RS449, EIA530, or 188C)
INT SET MIL449 CON INT SET MIL449 CON (xxx)	Prints current connector setting Selects the connector type (xxx = DTY [D-type] or TWI [twinax])
INT SET MIL449 EMU INT SET MIL449 EMU (xxx)	Prints current emulation setup Selects the type of emulation (xxx = DTE or DCE)
INT SET MIL449 MOD INT SET MIL449 MOD (xxx)	Prints current mode setting Selects the mode setting (xxx = BAL or UNBAL)
INT SET MIL449 IMP INT SET MIL449 IMP (xxx)	Prints the current termination impedance Selects the termination impedance (xxx = 78, 100, 124, or UNTERM)
INT SET MIL449 TIM INT SET MIL449 TIM (xxx)	Prints the current timing Selects the timing (xxx = ASY or SYN)
INT SET MIL449 RCV (xx)	Selects the receive clock source (xx = TT or ST)
INT SET MIL449 DAT INT SET MIL449 DAT (x)	Prints the current data bits setting Selects the data bits (x = 5, 6, 7, or 8)
INT SET MIL449 PAR INT SET MIL449 PAR (xxx)	Prints the current parity setting Selects the parity (xxx = NON, EVE, or ODD)
INT SET MIL449 STO INT SET MIL449 STO (xxx)	Prints the current stop bit setting Selects the stop bit (xxx = 1, 1.5, or 2)
INT SET MIL449 TM (xxx)	Selects the Test Mode ON or OFF
INT SET MIL449 CTS (xxx)	Selects the Clear To Send ON or OFF
INT SET MIL449 LL (xxx)	Selects the Local Loop ON or OFF
INT SET MIL449 RL (xxx)	Selects the Remote Loop ON or OFF
INT MIL449 SIG INT MIL449 SIG (xxx)	Prints the current signaling polarity Selects the signaling polarity POS or NEG



## FIREBERD 4000 APPLICATIONS

### 4.1 INTRODUCTION

This section shows how the RS-449/530/MIL Interface can be used with the FIREBERD 4000 in a variety of test scenarios. Test and instrument set-ups are provided for:

- (1) Testing the Near-End Modem (Local Loopback) or the Far-End Modem (Remote Loopback)
- (2) Testing a Far-End 64 kb/s Sub-Rate Channel (Remote Loopback)
- (3) Testing Near- and Far-End 256 kb/s Equipment Simultaneously
- (4) Testing a 1200 b/s Asynchronous Modem (Local Loopback)

**NOTE:** The combination of test applications is purely arbitrary. The procedures in this section are written so that a variety of applications could be described. Any combination is possible, depending on the available facilities.

The procedures in this section assume that you possess a working knowledge of the RS-449/530/MIL Interface and the FIREBERD. If you are unfamiliar with the instruments, please refer to Section 3, Installation and Operation.

### 4.2 SYNCHRONOUS TESTING

#### 4.2.1 Testing the Near-End Modem (Local Loopback) or the Far-End Modem (Remote Loopback)

Figure 4-1 shows a FIREBERD 4000 with the RS-449/530/MIL Interface. The instrument is connected to a near-end 9600 b/s modem (MODEM #1) and a far-end 9600 b/s modem (MODEM #2). By looping either modem output back to its own input the FIREBERD can transmit test data to either the local modem or the remote modem and analyze the looped-back data for errors.

#### 4.2.2 Testing the Far-End Subrate Channel

Figure 4-2 shows a FIREBERD 4000 equipped with the RS-449/530/MIL Interface testing a far-end sub-rate channel by creating a remote loopback. The instrument is connected to a 64 kb/s sub-rate channel of a multiplexer on the near side. The far-end multiplexer has its 64 kb/s sub-rate channels output connected to its own input to form a loop. The FIREBERD generates data and analyzes the received data for errors.

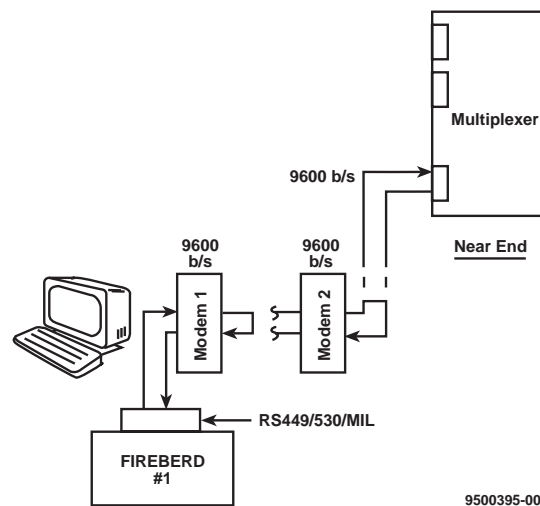

**Figure 4-1**  
**Local and Remote Loopback Testing**

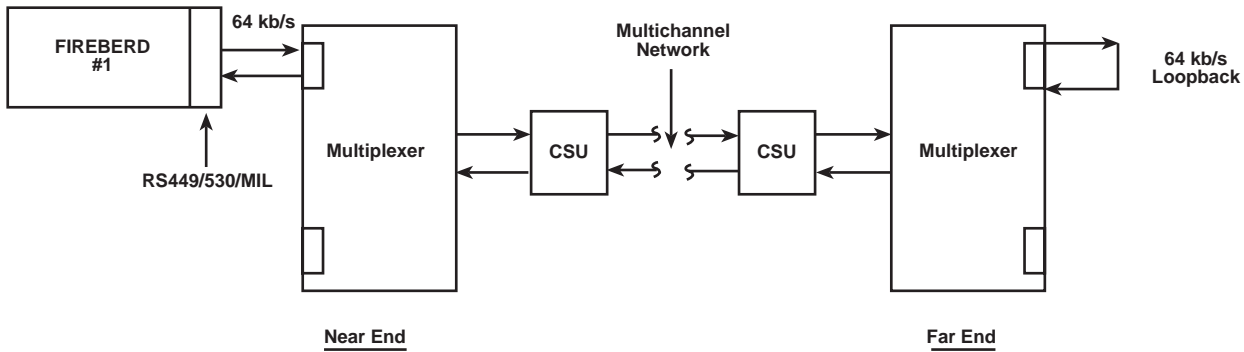

9500396-00

**Figure 4-2**  
**Testing a Far-End Substrate Channel**

### 4.2.3 Basic Synchronous Test Set-Up

Table 4-1 describes the FIREBERD 4000 set-up procedures for the two basic bit error rate tests described in this section. Although these procedures specifically apply to the

testing of modems and multiplexers using the EIA-530 connector, you can use them to set up any basic synchronous test using the RS-449/530/MIL Interface.

**Table 4-1**  
**FIREBERD 4000 Synchronous Test Set-Up With EIA-530**

Step	Activity
1.	With the power to the FIREBERD 4000 turned off, insert the RS-449/530/MIL Data Interface in the designated rear-panel slot.
2.	Press the POWER switch to apply power to the FIREBERD 4000.  <b>RESULT:</b> The SETUP display shows the units current configuration.  <b>NOTE:</b> If the FIREBERD 4000 is in Self-Loop mode after power-up, disengage the SELF LOOP switch.
3.	Set the SETUP CATEGORY switch from SETUP SUMMARY category to the INTERFACE category.



**Table 4-1**  
**FIREBERD 4000 Synchronous Test Set-Up With EIA-530 (Continued)**

Step	Activity
4.	<p>Using the SETUP SELECT switch and the softkeys underneath the SETUP display, configure the INTERFACE SETUP menu as follows:</p> <p><b>NOTE:</b> Unless indicated, press the right half of the SETUP SELECT switch once between selections.</p> <p>Select:</p> <ol style="list-style-type: none"> <li>1. MIL449 to select the RS-449/530/MIL Interface.</li> <li>2. EIA530 to select the type of interface.</li> <li>3. DTE to select DTE emulation.</li> <li>4. BAL to select balanced mode.</li> <li>5. IMPEDANCE as required (78, 100, 124, or UNTERM).</li> <li>6. SYNC to select synchronous timing.</li> <li>7. Select LL (Local Loop) or RL (Remote Loop) ON or OFF depending on the test.</li> <li>8. ON to select Signaling positive.</li> </ol>
5.	Set the SETUP CATEGORY switch from INTERFACE SETUP category to the GENERATOR CLOCK category.
6.	Set the GENERATOR CLOCK to INTF to receive the clock from the DCE.
7.	Set the SETUP CATEGORY switch from GENERATOR CLOCK category to the PATTERN category.
8.	<p>Using the MORE key and the appropriate softkey, select a test data pattern.</p> <p><b>NOTE:</b> If transmitting test data to either the local modem or the remote modem as shown in Figure 4-1, select either the 511, or the 2047 data pattern.</p> <p><b>NOTE:</b> If testing a 64 kb/s substrate channel as shown in Figure 4-2, it is recommended to select 2047 or 2<sup>15</sup>-1 data pattern.</p>
9.	<p>If hard copy test results are desired, set the PRINTER switch to print on a time interval (15 MIN or 1 HR) or on the occurrence of any error condition (ERROR).</p> <p><b>NOTE:</b> Both error and time print events can be customized using the AUX PRINT EVENT auxiliary function. See Section 3 of the <i>FIREBERD 4000 Reference Manual</i> for detailed instructions.</p>
10.	Press the RTS and DTR switches (located to the right of the VOLUME control) to set both signaling leads HIGH. Both switches will illuminated.
11.	Using the appropriate cables, connect the FIREBERD 4000 to the equipment under test.
12.	If performing a loopback test, establish a loop by performing the procedures which are appropriate for your DCE.
13.	Check that the PATTERN SYNC and CLOCK PRES LEDs located at the upper right-hand corner of the FIREBERD 4000 are illuminated.
	<b>RESULT:</b> The FIREBERD 4000 has achieved pattern synchronization, and is gathering test results.

#### 4.2.4 End-to-End Synchronous Testing

Figure 4-3 shows two FIREBERD 4000s, each equipped with the RS-449/530/MIL Interface. FIREBERD #1 connects to the 256 kb/s sub-rate channel of the multiplexer at the near end. FIREBERD #2 connects to the 256 kb/s sub-rate channel of the multiplexer at the far end. Both instruments simultaneously generate test data and analyze received data for errors in both directions.

The test results obtained in this configuration reflect the quality of all the lines and equipment between the two FIREBERDS.

Table 4-2 describes the FIREBERD 4000 setup procedures for the bit error rate test illustrated in Figure 4-3. Although these procedures specifically apply to the testing of modems and multiplexers using the RS-449 connector, you can use them to set up any basic synchronous test using the RS-449/530/MIL Interface.

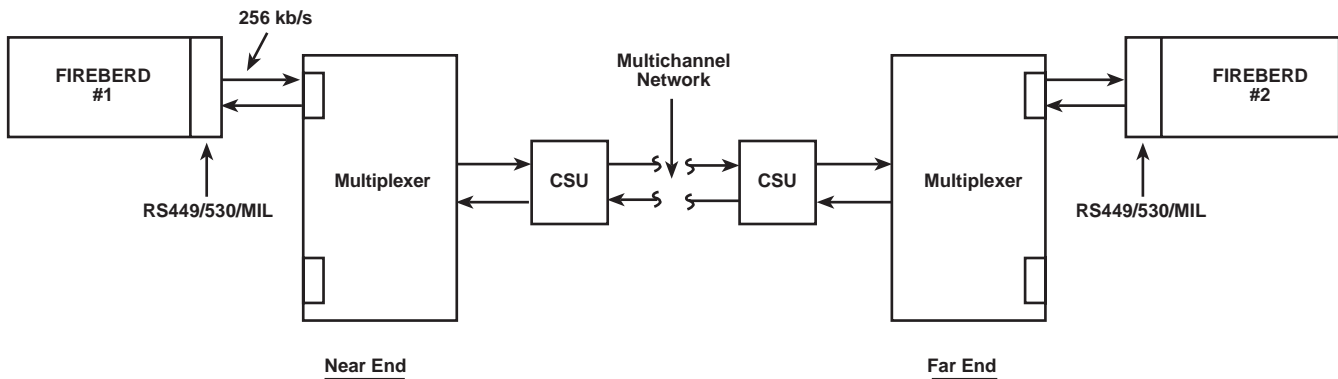

9500397-00

**Figure 4-3**  
Testing Near- and Far-End Subrate Equipment Simultaneously

**Table 4-2**  
FIREBERD 4000 Synchronous Test Set-Up With RS-449

Step	Activity
1.	With the power to the FIREBERD 4000 turned off, insert the RS-449/530/MIL Data Interface in the designated rear-panel slot.
2.	Press the POWER switch to apply power to the FIREBERD 4000.  <b>RESULT:</b> The SETUP display shows the units current configuration.  If the FIREBERD 4000 is in Self-Loop mode after power-up, disengage the SELF LOOP switch.
3.	Set the SETUP CATEGORY switch to the INTERFACE category.
4.	Using the SETUP SELECT switch and the softkeys underneath the SETUP display, configure the INTERFACE SETUP menu as follows:  <b>NOTE:</b> Unless indicated, press the right half of the SETUP SELECT switch once between selections.

**Table 4-2  
FIREBERD 4000 Synchronous Test Set-Up With RS-449 (Continued)**

Step	Activity
	<p>Select:</p> <ol style="list-style-type: none"> <li>1. MIL449 to select the RS-449/530/MIL Interface.</li> <li>2. RS449 to select the type of interface.</li> <li>3. D-TYPE to select the type of connector.</li> <li>4. DTE to select DTE emulation.</li> <li>5. BAL to select balanced mode.</li> <li>6. IMPEDANCE as required (78, 100, 124, or UNTERM)</li> <li>7. SYNC to select synchronous timing.</li> <li>8. Select LL (Local Loop) or RL (Remote Loop) ON or OFF depending on the test.</li> <li>9. ON to select Signaling positive.</li> </ol> <p>5. Set the SETUP CATEGORY switch to the GENERATOR CLOCK category.</p> <p>6. Set the GENERATOR CLOCK to INTF to receive the clock from the DCE.</p> <p>7. Set the SETUP CATEGORY switch to the PATTERN category.</p> <p>8. Using the MORE key and the appropriate softkey, select a test data pattern.</p> <p><b>NOTE:</b> If testing a 256 kb/s substrate channel as shown in Figure 4-3, select either the 511 or the 2047 data pattern.</p> <p>9. If hard copy test results are desired, set the PRINTER switch to print on a time interval (15 MIN or 1 HR) or on the occurrence of any error condition (ERROR).</p> <p><b>NOTE:</b> Both error and time print events can be customized using the AUX PRINT EVENT auxiliary function. See Section 3 of the <i>FIREBERD 4000 Reference Manual</i> for detailed instructions.</p> <p>10. Press the RTS and DTR switches (located to the right of the VOLUME control) to set both signaling leads HIGH. Both switches will illuminated.</p> <p>11. Using the appropriate cables, connect the FIREBERD 4000 to the equipment under test.</p> <p>12. If performing a loopback test, establish a loop by performing the procedures which are appropriate for your DCE.</p> <p>13. Check that the PATTERN SYNC and CLOCK PRES LEDs located at the upper right-hand corner of the FIREBERD 4000 are illuminated.</p> <p><b>RESULT:</b> The FIREBERD 4000 has achieved pattern synchronization, and is gathering test results.</p>

## 4.2.5 Synchronous Test Results

Table 4-3 lists the significant synchronous test results that are available with the RS449/MIL Data Interface. These results can be collected via printer or can be viewed at the ANALYSIS display windows.

## 4.3 ASYNCHRONOUS TESTING

### 4.3.1 Testing a 1200 b/s Asynchronous Modem (Local Loopback)

Figure 4-4 shows a FIREBERD 4000 equipped with the RS-449/530/MIL Interface. The instrument is connected to a 1200 b/s modem which has its output looped back to its own input. The FIREBERD 4000 both transmits the test data and analyzes the received data for errors.

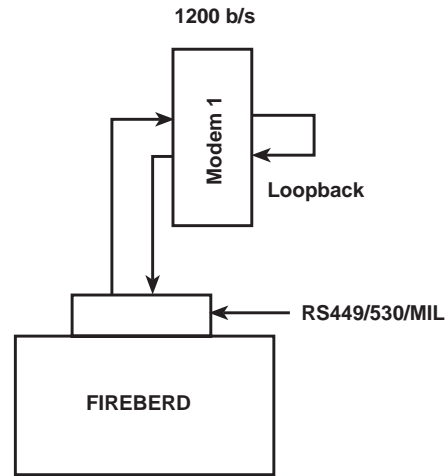

9500398-00

**Figure 4-4**  
Testing an Asynchronous Modem

**Table 4-3**  
FIREBERD 4000 Synchronous Test Results

Category	Results		
ERROR	BER AVG BLER AVG BER	BLOCKS CLK SLIP PAT LOSS	BLK ERRS BIT ERRS PAT SLIP <sup>2</sup>
PERFORMANCE <sup>1</sup>	GERR SEC DEG MIN %SES %AVL SEC	GEFS %DEG MIN UNA SEC	G %EFS SES AVL SEC
TIME & SIGNAL	ERR SEC ELAP SEC PATL SEC GEN FREQ	TEST SEC TIME DELAY <sup>3</sup>	%EFS DATE RCV FREQ

<sup>1</sup>Requires option 4004

<sup>2</sup>Synchronous timing with pseudorandom timing only

<sup>3</sup>DTE only

**Table 4-4  
FIREBERD 4000 Asynchronous Test Set-Up With 188C**

Step	Activity
1.	With the power to the FIREBERD 4000 turned off, insert the RS-449/530/MIL Data Interface in the designated rear-panel slot.
2.	Press the POWER switch to apply power to the FIREBERD 4000.
	<p><b>RESULT:</b> The SETUP display shows the units current configuration.</p> <p>If the FIREBERD 4000 is in Self-Loop mode after power-up, disengage the SELF LOOP switch.</p>
3.	Set the SETUP CATEGORY switch to the INTERFACE category.
4.	Using the SETUP SELECT switch and the softkeys underneath the SETUP display, configure the INTERFACE SETUP menu as follows:
	<p><b>NOTE:</b> Unless indicated, press the right half of the SETUP SELECT switch once between selections.</p> <p>Select:</p> <ol style="list-style-type: none"> <li>1. MIL449 to select the RS-449/530/MIL Interface.</li> <li>2. 188C to select the type of interface.</li> <li>3. DTE to select DTE emulation.</li> <li>4. ASYNC to select asynchronous timing.</li> <li>5. DATA BITS as required (5, 6, 7, or 8).</li> <li>6. PARITY as required (ODD, EVEN, or NONE).</li> <li>7. STOP BITS as required (1, 1.5, or 2).</li> <li>8. Select LL (Local Loop) or RL (Remote Loop) ON or OFF depending on the test.</li> <li>9. ON to select Signaling positive.</li> </ol>
5.	Set the SETUP CATEGORY switch to the GENERATOR CLOCK category.
6.	Set the GENERATOR CLOCK to INTRNL position.
7.	Using the SETUP SELECT switch and the appropriate softkey, set the INTERNAL FREQ to 1.2 k.
8.	Set the SETUP CATEGORY switch to the PATTERN category.
9.	Using the MORE key and the appropriate softkey, select the FOX data pattern.
10.	If hard copy test results are desired, set the PRINTER switch to print on a time interval (15 MIN or 1 HR) or on the occurrence of any error condition (ERROR).
	<p><b>NOTE:</b> Both error and time print events can be customized using the AUX PRINT EVENT auxiliary function. See Section 3 of the <i>FIREBERD 4000 Reference Manual</i> for detailed instructions.</p>
11.	Press the RTS and DTR switches (located to the right of the VOLUME control) to set both signaling leads HIGH. Both switches will illuminated.
12.	Using the appropriate cables, connect the FIREBERD 4000 to the equipment under test.
13.	If performing a loopback test, establish a loop by performing the procedures which are appropriate for you DCE.
14.	Check that the PATTERN SYNC and CLOCK PRES LEDs located at the upper right-hand corner of the FIREBERD 4000 are illuminated.
	<p><b>RESULT:</b> The FIREBERD 4000 has achieved pattern synchronization, and is gathering test results.</p>

### 4.3.2 Asynchronous Test Results

Table 4-5 lists the significant asynchronous test results that are available with the RS449/MIL Data Interface. These results can be collected via printer or can be viewed at the ANALYSIS display windows.

**Table 4-5  
FIREBER 4000 Asynchronous Test Results**

Category	Results		
ERROR	BIT ERRS BLOCKS CHAR ERR	AVG BER BLK ERRS PAT LOSS	BER AVG BLER
PERFORMANCE <sup>1</sup>	UNA SEC AVL SEC %DEG MIN G %EFS	%AVL SEC SES SYNL SEC GERR SEC	DEG MIN %SES %SYN SEC G EFS
TIME & SIGNAL	ERR EAS ELAP SEC PATL SEC DELAY <sup>2</sup> ELAP SEC	E A SEC TIME ERR SEC GEN FREQ	E F EAS DATE %EFS TEST SEC

<sup>1</sup>Requires option 4004

<sup>2</sup>DTE only

## FIREBERD 6000 INSTALLATION AND OPERATION

### 5.1 INTRODUCTION

This section describes how to install, configure, and operate the RS-449/530/MIL Data Interface with a FIREBERD 6000. Refer to the *FIREBERD 6000 User's Guide* or the *FIREBERD 6000 Reference Manual* for mainframe operating procedures.

**NOTE:** Configure the FIREBERD 6000 and the RS-449/530/MIL Data Interface before connecting the FIREBERD to the circuit under test. This avoids unnecessary circuit downtime.

#### 5.1.1 Repair and Replace Procedure

The RS-449/530/MIL Data Interface, Model 41400, is provided as a self-contained unit. If repairs are necessary, the entire interface should be replaced. Section 8 of this manual contains information about the warranty and return policies.

### 5.2 INSTALLING THE INTERFACE

The following procedure describes how to install the RS-449/530/MIL Data Interface in the FIREBERD 6000. Figure 5-1 illustrates how the interface is installed.

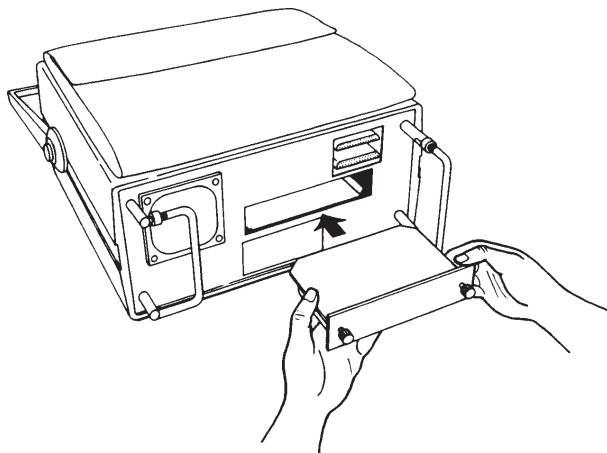

9500399-00

**Figure 5-1**  
**Installing a Modular Interface**

**CAUTION:** Before installing or removing the interface module, turn the AC power OFF to the FIREBERD mainframe. Damage can occur to the interface and mainframe.

#### 5.2.1 Performance Verification

The proper performance of the RS-449/530/MIL Data Interface, Model 41400, is verified by installing the interface in the FIREBERD 6000 as described in the previous paragraphs. The FIREBERD 6000 should be set-up as described in the step-by-step procedures in the following paragraphs. The equipment should be powered-up and the various menus and set-ups performed to ensure proper operation. If any test fails, be sure to check connections, continuity of cables, and proper seating of the interface into results section at the back of this section. In addition, the *FIREBERD 6000 Reference Manual* provides additional performance verification and validation results.

#### 5.2.2 Calibration Procedures

The RS-449/530/MIL Data Interface, Model 41400, is factory checked and requires no calibration. The FIREBERD 6000 is calibrated as described in the *FIREBERD 6000 Reference Manual*.

#### 5.2.3 Parts List and Vendors List

No parts list or vendors list is provided because the RS-449/530/MIL Data Interface, Model 41400, is the LRU. See Section 8 of this manual for replacement and warranty information.

1. Power OFF the FIREBERD.
2. Face the FIREBERD rear panel.
3. Insert the interface into the vacant interface slot. Verify that the interface faces up.
4. Slide the module into the FIREBERD until the interface panel is flush with the rear panel. Make sure the PC board edges are fitted into the card guides inside the interface slot.
5. Secure the interface with the two thumbscrews on the interface panel.

### 5.3 FIREBERD 6000 MAINFRAME SET-UP

Perform this procedure to configure the FIREBERD 6000 with the RS-449/530/MIL Interface.

- (1) Turn the AC power ON. If necessary, release the SELF LOOP pushbutton before starting.
- (2) Set the DATA switch to the appropriate test pattern. Refer to the *FIREBERD 6000 Reference Manual* for descriptions of the test patterns.
- (3) Set the GEN CLK switch to the appropriate generator clock source:

**SYNTH** - If the synthesizer is selected, use the MENU switch to select the SYNTH FREQ (synthesizer frequency) menu. Select the desired frequency from the softkeys or enter it through the keypad from 50 k b/s to 15 Mb/s.

**INTF** - Provides the generator clock through the interface received clock in synchronous mode and in recovered clock mode.

**BNC** - Allows an input from an external clock source. The external clock source is input through the GEN CLK IN connector on the rear panel.

- (4) Set the TIMING MODE switch to the appropriate timing mode as required:

**SYNC** - Selects the synchronous timing mode. With synchronous timing, operation to 15 Mb/s is possible. The default is SYNC.

**ASYNCR** - Select the asynchronous timing mode. Asynchronous timing is limited to data rates up to 20 kb/s. The following PATTERNS are valid in asynchronous testing: MARK, SPACE, 1:1, 63, 511, 2047, 215-1, FOX, and USER 1-3. When using asynchronous timing, set the MENU switch to the CHAR FORMAT menu to select DATA BITS, PARITY, and STOP BITS.

**RECOVD** - Selects the recovered timing mode.

- (5) If the AUX FUNC IN USE indicator is illuminated scroll through the Auxiliary Function IN USE list to identify auxiliary functions that might affect the operation of the RS-449/530/MIL Interface.
- (6) Select the desired ANALYSIS MODE: CONTINUOUS or SINGLE.
- (7) Select the applicable categories and results displays from the ANALYSIS RESULTS panel.

### 5.4 FIREBERD 6000 INTERFACE SET-UP

This section describes how to access the interface menu and discusses each of the menu selections in the RS-449/530/MIL Data Interface menu.

The RS-449/530/MIL Data Interface is controlled through the FIREBERD 6000 INTERFACE SETUP category. Press the MIL449 softkey to access the MIL449 interface menu. Press the appropriate softkey to select a function or another menu. To return to the previous menu display press the mainframe keypad “up arrow” key. To return to the main interface menu, press the mainframe ENTER key. Press the softkeys to select a function as indicated by the softkey labels on the bottom line of the display. All interface menu settings are retained when power is removed from the mainframe. See Figures 5-2 through 5-5 for the interface menus.

#### 5.4.1 Operating Type Menu

The Operating Type (TYPE) menu allows the user to select either MIL188114, RS449, EIA530, or MIL188C as the type of interface operation. Press the appropriate softkey to select the desired operating type. Press the MORE key to display the 188C softkey label. Modifying TYPE will cause a test restart.

**188114** - The 188114 operating type configures the interface to be connected to a MIL188-114 compatible circuit.

**RS449** - The RS449 operating type configures the interface to be connected to a RS-449 compatible circuit.

**EIA530** - The EIA530 operating type configures the interface to be connected to a EIA-530 compatible circuit.

**188C** - The 188C operating type configures the interface to be connected to a MIL188C compatible circuit.



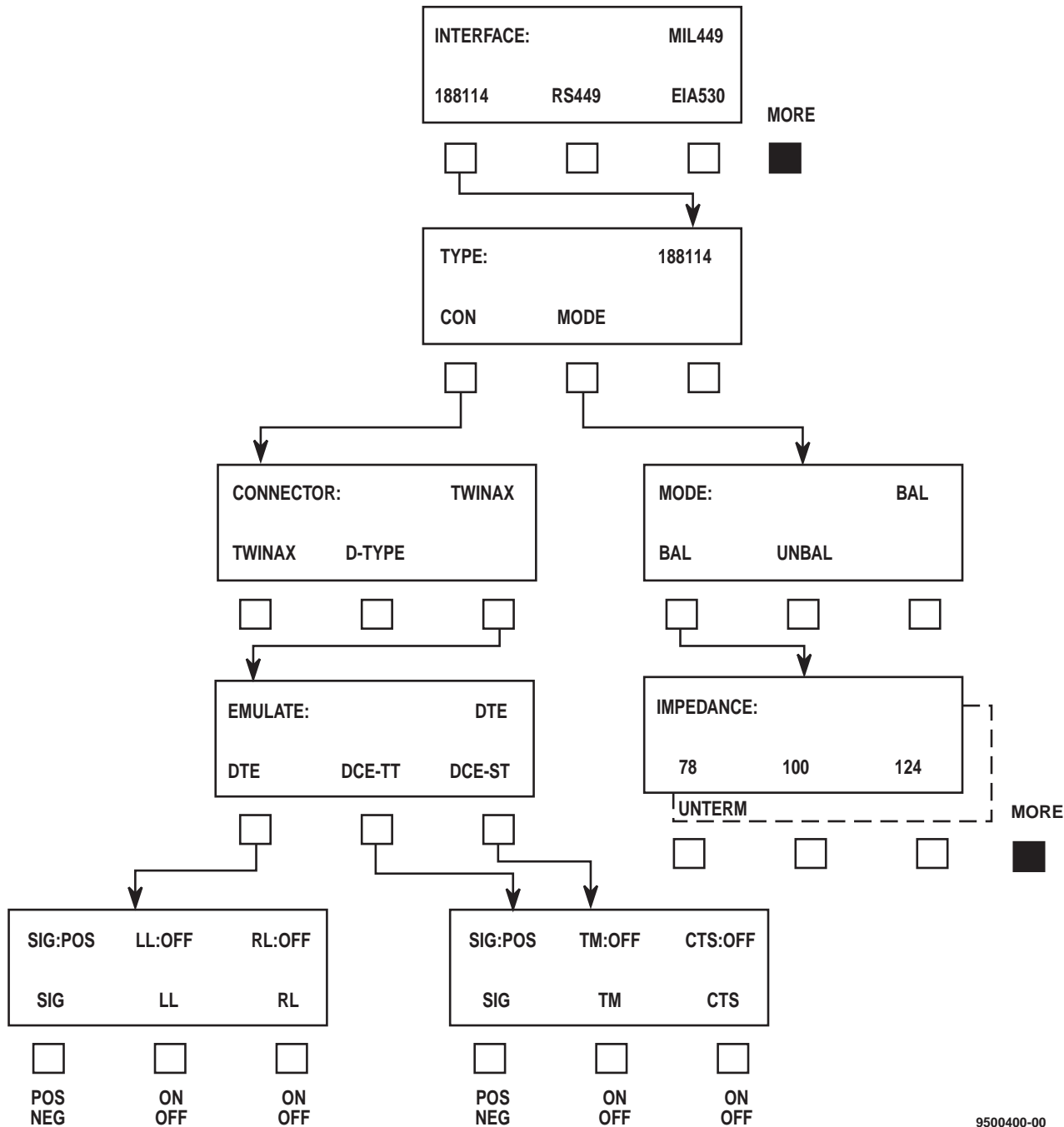
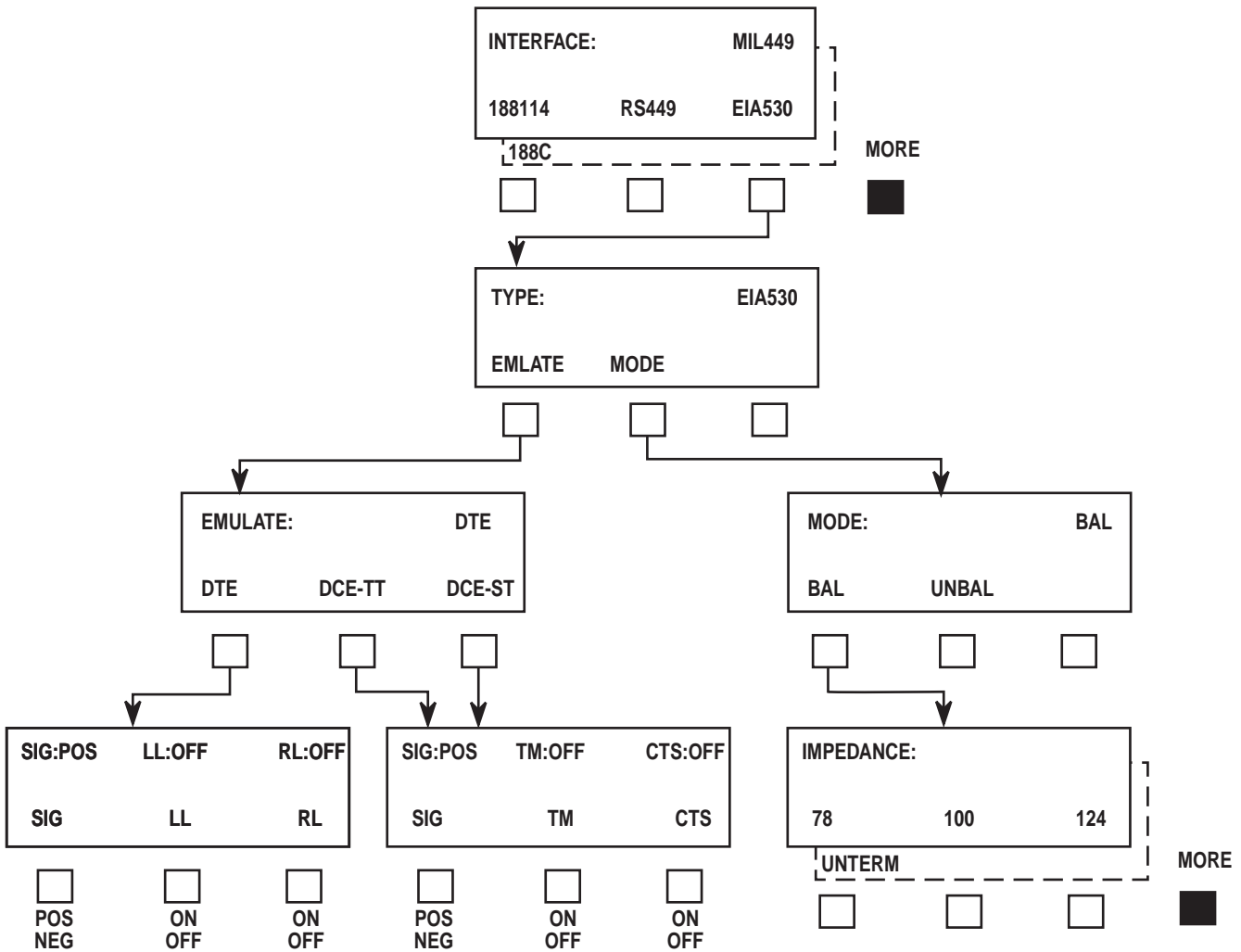
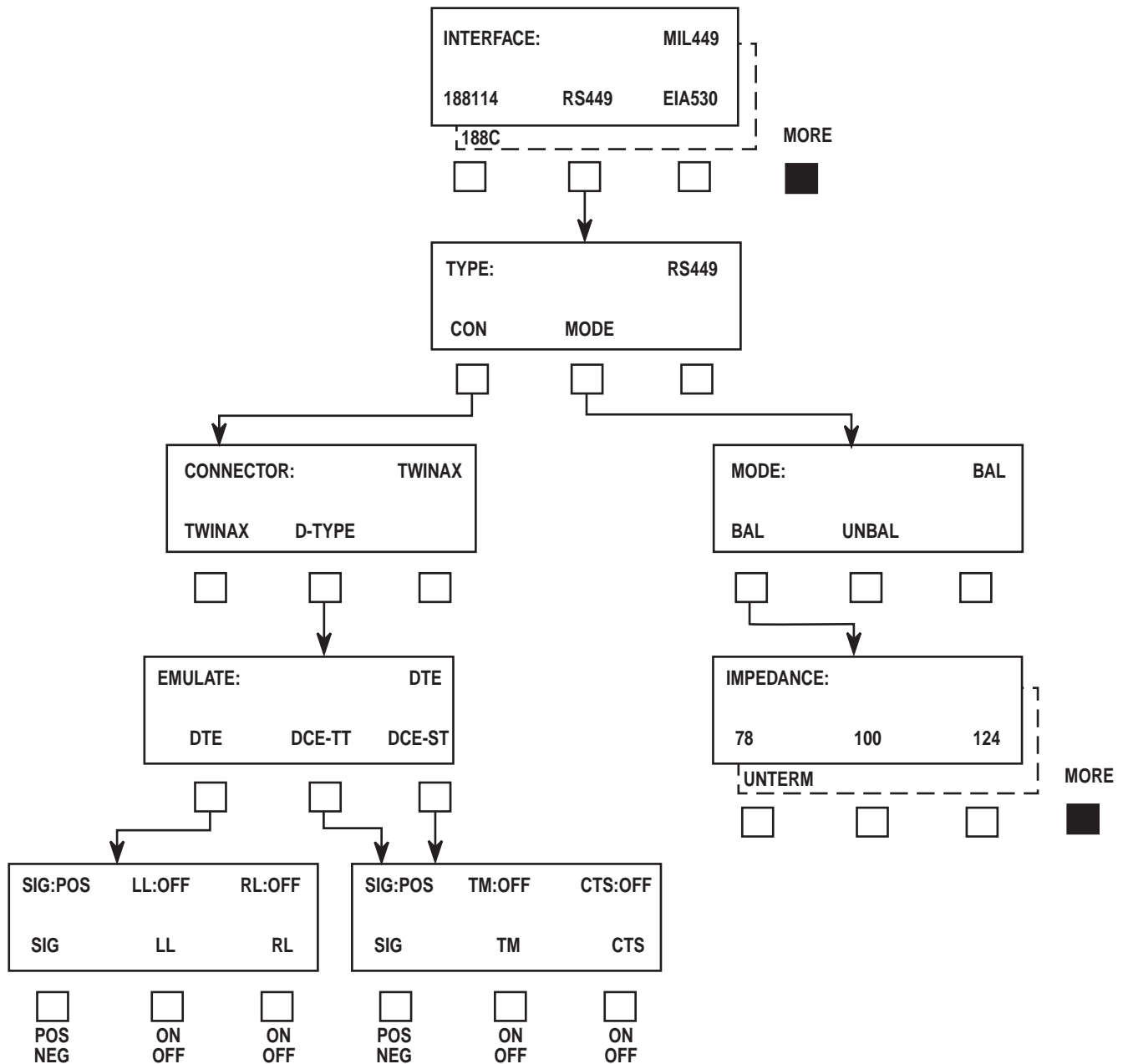

Figure 5-2  
 FIREBERD 6000 RS-449/530/MIL Interface Set-Up Menu  
 Type 188114



9500401-00

**Figure 5-3**  
**FIREBERD 6000 RS-449/530/MIL Interface Set-Up Menu**



Type EIA-530

Figure 5-4  
FIREBERD 6000 RS-449/530/MIL Interface Set-Up Menu

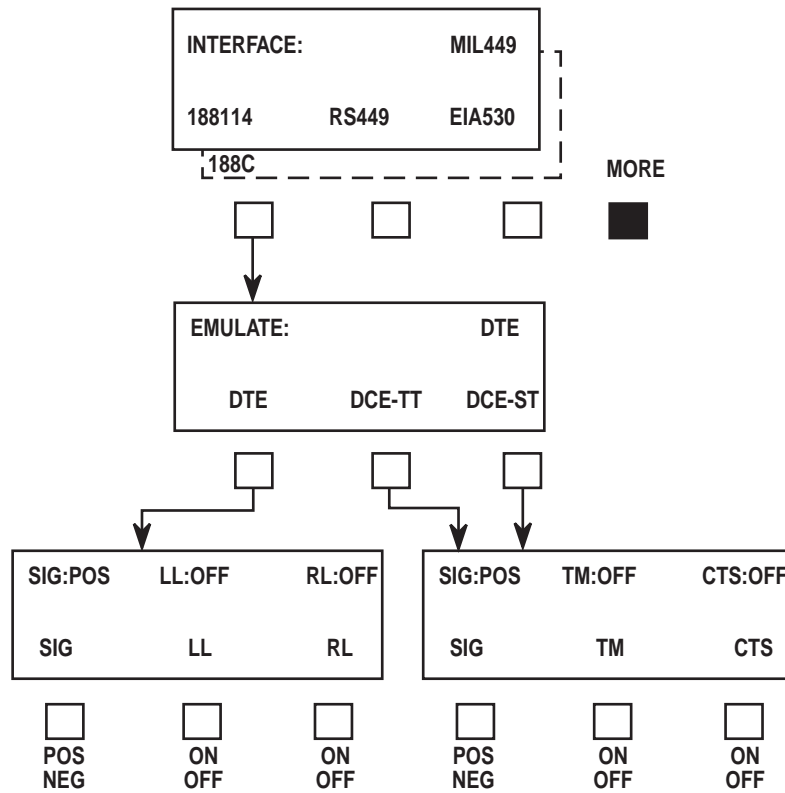

9500403-00

Type RS449

Figure 5-5  
FIREBERD 6000 RS-449 /530/MIL Interface Set-Up Menu  
Type 188C

### 5.4.2 Connector Menu

The Connector (CONNECTOR) menu only appears when TYPE 188114 or TYPE RS449 is selected. This menu controls the type of data interface which the FIREBERD can be connected to. Modifying CONNECTOR causes a test restart. Pressing the associated softkey selects either D-TYPE or TWINAX.

**D-TYPE** - When the D-TYPE softkey is pressed, the interface is configured to use the RS-449/MIL188-114, 37-pin connector.

**TWINAX** - When the TWINAX softkey is pressed, the interface is configured to use the twinax connectors.

### 5.4.3 Emulate Menu

The Emulate (EMULATE) menu establishes the interface emulation mode. Pressing the associated softkey selects either DTE or DCE emulation. This menu does not appear when the selected CONNECTOR is TWINAX.

**DTE** - This selection allows the FIREBERD mainframe to emulate DTE.

**DCE-TT** - This selection allows the FIREBERD mainframe to emulate DCE with Terminal Timing as the timing reference that the mainframe synchronizes to. In Terminal Timing the receiver timing source comes from Pin 24 (EIA530/MIL188C) or Pin 17 (RS-449/MIL188-114).

**DCE-ST** - This selection allows the FIREBERD mainframe to emulate DCE with Send Timing as the timing reference that the mainframe synchronizes to. In Send Timing the receiver timing source is the mainframe generator clock that is sent out on Pin 15 (EIA530/MIL188C) or Pin 5 (RS-449/MIL188-114).

### 5.4.4 Mode Menu

The Mode (MODE) menu allows the user to select between balanced and unbalanced operation. Modifying MODE causes a test restart.

**BAL** - This selection allows the FIREBERD to operate in a balanced mode. Balanced mode indicates that each signal is transmitted on two leads in which the voltage is equal in magnitude and opposite in polarity with respect to a common reference. This mode is preferred when minimum noise and cross talk is desired. When balanced mode is selected the following menu is provided to set the termination impedance. The termination impedance should be set to match the characteristics of the cable.

**IMPEDANCE** - This menu allows you to select either a termination impedance of 78 ohms, 100 ohms, 124 ohms, or UNTERM (>7.4 k ohms).

**UNBAL** - This selection allows the FIREBERD to operate in an unbalanced mode. In unbalanced mode each signal is transmitted on one lead with respect to a common ground.

### 5.4.5 Signaling Menu

**TM:OFF|ON CTS:OFF|ON** - This menu only appears when the mainframe is configured for D-TYPE CONNECTOR and DCE EMULATION. The operation of TM (Test Mode) lead [Pin 25 (EIA530/MIL188C) or Pin 18 (RS-449/MIL188-114)] and the operation of the CTS (Clear To Send) lead [Pin 5 (EIA530/MIL188C) or Pin 9 (RS-449/MIL188-114)] are controlled by this menu. Press the TM softkey to toggle the TM lead ON and OFF. ON equals a logic HIGH. OFF equals a logic LOW. Press the CTS softkey to toggle the CTS lead ON and OFF. ON equals a logic HIGH. OFF equals a logic LOW.

**LL:OFF|ON RL:OFF|ON** - This menu only appears when the mainframe is configured for D-TYPE CONNECTOR and DTE EMULATION. The operation of the LL (Local Loopback) lead [Pin 18 (EIA530/MIL188C) or Pin 10 (RS-449/MIL188-114)] and RL (Remote Loopback) lead [Pin 21 (EIA530/MIL188C) or pin 18 (RS-449/MIL188-114)] are controlled by this menu. Press the LL softkey to toggle the LL lead ON and OFF. ON equals a logic HIGH. OFF equals a logic LOW. Press the RL softkey to toggle the RL lead ON and OFF. ON equals a logic HIGH. OFF equals a logic LOW.

**SIG:POS|NEG** - This menu only appears when the D-TYPE CONNECTOR is selected. This menu controls the polarity of all the interface signaling control leads. Press the appropriate softkey to set SIG to POS (positive) or NEG (negative) polarity. Selecting POS sets the ON condition to a positive value and an OFF condition to a negative value. Selecting NEG sets the ON condition to a negative value and an OFF condition to a positive value.

## 5.5 FIREBERD 6000 ANALYSIS RESULTS

Table 5-1 lists the analysis results that are displayed when the RS-449/530/MIL Data Interface is installed in the FIREBERD 6000. Refer to the *FIREBERD 6000 Reference Manual* for results definitions.

**Table 5-1  
FIREBERD 6000 Analysis Results**

<b>Category</b>	<b>Displayed Result</b>	<b>Description</b>
ERROR	AVG BER	Average Bit Error Rate
	AVG BLER	Average Block Error Rate
	BER	Bit Error Rate
	BIT ERRS	Bit Errors
	BLOCKS	Blocks
	BLK ERRS	Block Errors
	CHAR ERR	Character Error**
	PAT SLIP	Pattern Slips*
TIME	DATE	Date
	EA SEC	Error Analysis Seconds
	EF EAS	Error-Free Error Analysis Seconds
	ELAP SEC	Elapsed Seconds
	ERR EAS	Errored Error Analysis Seconds
	PATL SEC	Pattern Loss Seconds
	%PAT SEC	%Pattern Loss Seconds
	TIME	Time
SIGNAL	DELAY	Delay
	GEN FREQ	Generator Frequency
	RCV FREQ	Receiver Clock Frequency*
ALARM	C-D CHA	Receiver Clock-Data Phase Changes****
	CLK LOSS	Receiver Clock Losses***
	DAT LOSS	Receiver Data Losses
	PAT LOSS	Pattern Synchronization Loss
	PWR LOSS	Power Losses
PERFORMANCE*	AVL SEC	Available Seconds
	%AVL SEC	% Available Seconds
	%DEG MIN	% Degraded Minutes
	%PAT SEC	%Pattern Seconds
	%SES	% Severely Errored Seconds
	BER-SES	BIT Error Rate Minus Severely Errored Seconds
	DEG MIN	Degraded Minutes
	ERR-SES	Errors Minus Severely Errored Seconds
	G EFS	G.821 Percent of Error Free Seconds
	GERR SEC	G.821 Errored Seconds
	G %EFS	G.821 Percent of Error Free Seconds
	SES	Severely Errored Seconds
	UNA SEC	Unavailable Seconds

If not indicated - Available with Synchronous, Asynchronous, and Recovered Timing

\*Available with Synchronous and Recovered Timing

\*\*Available with Asynchronous Timing Only

\*\*\*Available with Synchronous Timing Only

## 5.6 FIREBERD 6000 SELF-LOOP TEST

The RS-449/530/MIL Data Interface includes a relay that is activated by the SELF LOOP pushbutton switch on the FIREBERD front panel. Pressing the SELFLOOP pushbutton connects the transmit clock and data to the receive clock and data. This provides quick verification of the FIREBERD and the data interface. User connections do not need to be removed during the test, since complete isolation is provided by the relay when testing in the Self-Loop mode.

## 5.7 INTERFACE STATUS INDICATORS AND SWITCHES

Depending on the EMULATE selection (DTE or DCE) the corresponding front panel interface status and control panel label will illuminate. The LEDs to the right of these labels indicate activity on the associated interface connector lines. The following describes what each LED indicates. The DTE and DCE emulation labels not in parentheses indicate EIA 530/MIL-188C lead notation and the labels in parentheses indicate RS-449/MIL188-114 lead notation.

### Switches

**RLSD (RR)** - In DCE emulation the pushbutton switch controls the state of the Received Line Signal Detector line. Pressing the RLSD pushbutton causes it to illuminate, forcing this line ON. When the pushbutton LED is extinguished, the line is held OFF.

**DSR (DM)** - In DCE emulation, pressing the corresponding pushbutton illuminates the LED and forces the DSR line ON. Pressing this pushbutton again extinguishes the LED and the DSR line is held OFF.

**RTS** - In DTE emulation, pressing the Request To send pushbutton illuminates the LED and forces this line ON. Pressing this pushbutton again extinguishes the LED and holds the line OFF.

**DTR** - In DTE emulation, pressing this pushbutton illuminates the LED and forces the Data Terminal Ready line ON.

### Indicators

**RLSD** - In DTE emulation, the Received Line Signal Detector illuminates when this line is ON.

**DSR** - In DTE emulation, the Data Set Ready LED illuminates when this line is ON.

**CTS** - In DTE emulation, the Clear To Send LED illuminates when this line is ON. In DCE emulation, there is no corresponding LED.

**RTS** - In DCE emulation, the Request To Send LED illuminates when this line is ON.

**DTR** - In DCE emulation, the LED illuminates when this line is ON.

**TM** - In DTE emulation, the Test Mode LED illuminates when this line is ON. In DCE emulation, there is no corresponding LED.

**LL** - In DCE emulation, the Local Loopback LED illuminates when this line is ON. In DTE emulation, there is no corresponding LED.

**RL** - In DCE emulation, the Remote Loopback LED illuminates when this line is ON. In DTE emulation, there is no corresponding LED.

## 5.8 FIREBERD 6000 PRINTER OPERATION

Refer to the *FIREBERD 6000 Reference Manual* for printer set-up and operating instructions. Figure 5-6 is a typical Controls printout showing a RS-449/530/MIL Data Interface. Figure 5-7 shows a typical Results printout with the RS-449/530/MIL Data Interface.

**NOTE:** Only the interface setting relevant to the current interface mode are displayed.

```
CONTROLS PRINT
10:33:03 06 DEC 90 SITE: Alpha
DATA: 2^15-1 ERROR INS: OFF
SELF LOOP: ON GEN CLOCK: SYNTH
TIMING MODE: SYNC SYN FRQ: 64 kHz
INTERFACE:
TYPE: RS449 EMULATE: DTE
MODE: BAL IMPEDANCE: 100
CONNECTOR D-TYPE POLARITY: POS
LL: OFF RL: OFF
RTS: OFF DTR: OFF
TEST INT: 10^5 PRINT EVENT: NOR
TEST INT: OFF SYNC LOSS PRNT: OFF
ERROR PRNT: OFF TIME PRNT: OFF
ANALY MODE: CON DISPLAY HOLD: OFF
BLOCK LENGTH: 1000 BITS
DELAY: DTR/ DTR/ XON CHARACTER: 11
XOFF CHARACTER: 13 AUX FUNC IN USE:
NONE PRINT SPEED: FAST
PRINT TERM: CR LF REMOTE: NONE
PRINTER: RS-232 RS-232:
DATA BITS: 8 BAUD: 9600
PARITY: NONE
```

**Figure 5-6**  
**Controls Printout**

```

MANUAL          PRINT
TIME/DATE      10:34:38 06 DEC 90
BIT ERRS       0      AVG BER       0.  E-08
BER            0.  E-05  BLOCKS        11542
BLK ERRS       0      AVG BLER      0.  E-04
EA SEC         180    ERR EAS        0
EF EAS         180    PAT SLIP       0
ELAP SEC       181    DELAY
RCV FREQ       64000.0  GEN FREQ      64000.0
PAT LOSS       0      DAT LOSS       0
CLK LOSS       0      PWR LOSS       0
C-D CHA        0      PATL SEC       0
%PAT SEC       100.00%  ERR-SES        0
BER-SES        0.  E-07  AVL SEC        180
%DEG MIN       0.00%  %SES           0.00%
G %EFS         100.00%  G EFS          180
DEG MIN        0      GERR SEC       0
SES            0      UNA SEC        0
%AVL SEC       100.00%  IF RS-449/530/MIL
RR             OFF    DM             OFF
CS             OFF    TM             OFF
RS             OFF    TR             OFF
SELF LOOP      ON

```

**Figure 5-7  
Results Printout**

## 5.9 FIREBERD 6000 REMOTE CONTROL COMMANDS

The FIREBERD 6000 remote control commands enable remote control over the RS-449/530/MIL Data Interface. The RS-449/530/MIL Data Interface commands are listed in Table 5-2. The commands are in accordance with the IEEE.488.2 specification. The spacing used on each command line must be used as indicated.

**Table 5-2  
RS-449/530/MIL Data Interface FIREBERD 6000 Remote Control Commands**

Remote Command	Result
INTF:MIL449:INTERFACE? INTF:MIL449:INTERFACE [188114 RS449 EIA530 188C]	Prints current interface type set-up. Selects the interface type.
INTF:MIL449:CONNECTOR? INTF:MIL449:CONNECTOR [TWINAX DTYPE]	Prints the current connector setting. Selects the connector type.
INTF:MIL449:CONNECTOR:DTYPE? INTF:MIL449:CONNECTOR:DTYPE [DTE DCE_TT DCE_ST]	Prints the current emulation for the D-Type connector. Selects the emulation type for the D-Type connector.
INTF:MIL449:EMULATE:SIGNAL? INTF:MIL449:EMULATE:SIGNAL [POSITIVE NEGATIVE] INTF:MIL449:EMULATE:LL? INTF:MIL449:EMULATE:LL [ON OFF]	Prints the current signaling polarity. Selects the signaling polarity POS or NEG. Prints the current Local Loop status. Selects the Local Loop ON or OFF.
INTF:MIL449:EMULATE:RL? INTF:MIL449:EMULATE:RL [ON OFF]	Prints the current Remote Loop status. Selects the Remote Loop ON or OFF.
INTF:MIL449:EMULATE:TM? INTF:MIL449:EMULATE:TM [ON OFF]	Prints the current Test Mode status. Selects the Test Mode ON or OFF.
INTF:MIL449:EMULATE:CTS? INTF:MIL449:EMULATE:CTS [ON OFF]	Prints the current Clear To Send status. Selects the Clear To Send ON or OFF.
INTF:MIL449:MODE? INTF:MIL449:MODE [BALANCE UNBALANCE]	Prints current mode setting. Selects the mode setting.
INTF:MIL449:BALANCE:IMPEDANCE? INTF:MIL449:BALANCE:IMPEDANCE [78 100 124 UNTERMINATE]	Prints the currently selected impedance. Select the impedance.



## FIREBERD 6000 APPLICATIONS

### 6.1 INTRODUCTION

This section shows how the RS-449/530/MIL Interface can be used with the FIREBERD 6000 in a variety of test scenarios. Test and instrument set-ups are provided for:

- (1) Testing the Near-End Modem (Local Loopback) or the Far-End Modem (Remote Loopback)
- (2) Testing a Far-End 64 kb/s Sub-Rate Channel (Remote Loopback)
- (3) Testing Near- and Far-End 256 kb/s Equipment Simultaneously
- (4) Testing a 1200 kb/s Asynchronous Modem (Local Loopback)

**NOTE:** The combination of test applications is purely arbitrary. The procedures in this section are written so that a variety of applications could be described. Any combination is possible, depending on the available facilities.

The procedures in this section assume that you possess a working knowledge of the RS-449/530/MIL Interface and the FIREBERD 6000. If you are unfamiliar with the instruments, please refer to Section 5, Installation and Operation.

### 6.2 SYNCHRONOUS TESTING

#### 6.2.1 Testing the Near-End Modem (Local Loopback) or the Far-End Modem (Remote Loopback)

Figure 6-1 shows a FIREBERD 6000 with the RS-449/530/MIL Interface. The instrument is connected to a near-end 9600 b/s modem (MODEM #1) and a far-end 9600 b/s modem (MODEM #2). By looping either modem output back to its own input the FIREBERD can transmit test data to either the local modem or the remote modem and analyze the looped-back data for errors.

#### 6.2.2 Testing the Far-End Subrate Channel

Figure 6-2 shows a FIREBERD 6000 equipped with the RS-449/530/MIL Interface testing a far-end sub-rate channel by creating a remote loopback. The instrument is connected to a 64 kb/s sub-rate channel of a multiplexer on the near side. The far-end multiplexer has its 64 kb/s sub-rate channels output connected to its own input to form a loop. The FIREBERD generates data and analyzes the received data for errors.

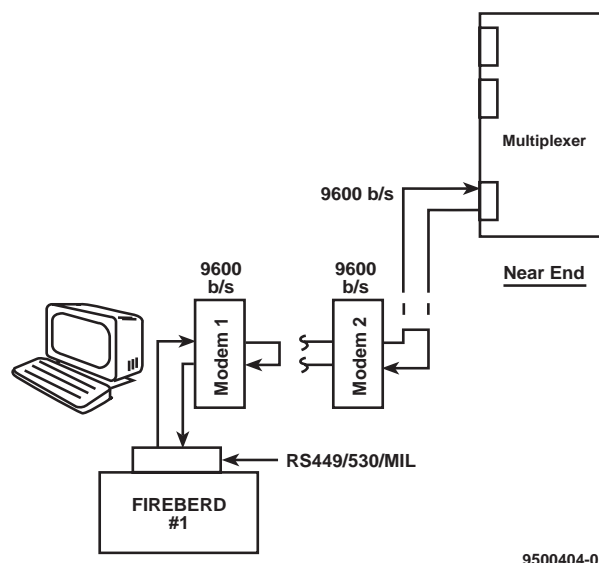

9500404-00

**Figure 6-1**  
**Local and Remote Loopback Testing**

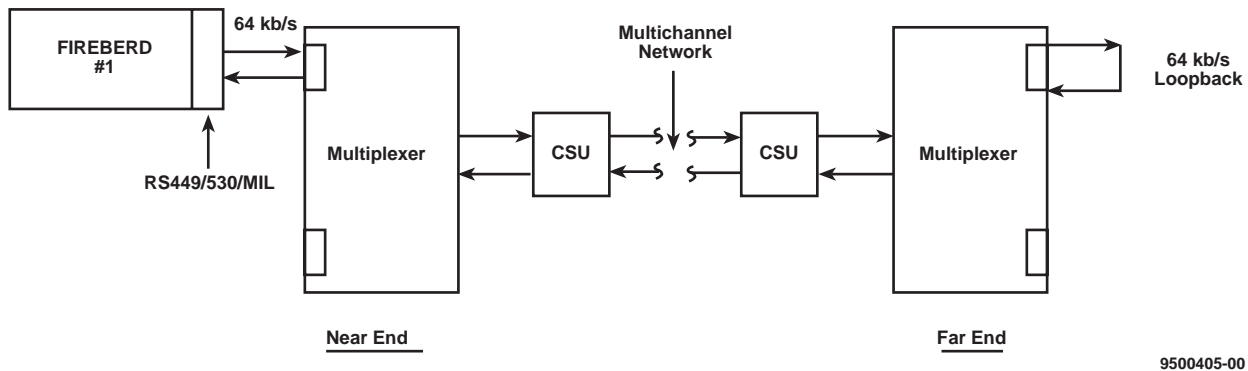

**Figure 6-2**  
**Testing a Far-End Substrate Channel**

### 6.2.3 Basic Synchronous Test Set-Up

Table 6-1 describes the FIREBERD 6000 set-up procedures for the two basic bit error rate tests described in this section. Although these procedures specifically apply to the

testing of modems and multiplexers using the EIA-530 connector, you can use them to set up any basic synchronous test using the RS-449/530/MIL Interface.

**Table 6-1**  
**FIREBERD 6000 Synchronous Test Set-Up With EIA-530**

Step	Activity
1.	With the power to the FIREBERD 6000 turned OFF, insert the RS-449/530/MIL Data Interface into the rear-panel interface slot.
2.	Press the POWER switch to apply power to the FIREBERD 6000.  <b>RESULT:</b> The SETUP display shows the units current configuration.  <b>NOTE:</b> If the FIREBERD 6000 is in Self-Loop mode after power-up, disengage the SELF LOOP switch.
3.	Set the DATA switch to either the 511 or the 2047 data pattern if transmitting test data to either the local modem or the remote modem. If testing a 64 kb/s substrate channel as shown in Figure 6-2 it is recommended to select 2047 or 2 <sup>15</sup> -1 as the data pattern.

**Table 6-1**  
**FIREBERD 6000 Synchronous Test Set-Up With EIA-530 (Continued)**

Step	Activity
4.	Set the GEN CLK switch to the INF position to receive the clock from the DCE.
5.	Set the TIMING MODE switch to the SYNC position.
6.	Set the MENU switch to the INTF SETUP position. Configure the RS449/530/MIL Data Interface as follows:  Select 1. MIL449 to select the RS-449/530/MIL Interface. 2. EIA 530 to select the type of interface. 3. EMULATE to select DTE emulation. 4. SIGnaling to POSitive. 5. LL (Local Loop) and RL (Remote Loopback) ON or OFF depending on the test. 6. Press the up arrow on the MENU keypad. 7. MODE to select the mode menu. 8. BAL for balanced mode. 9. IMPEDANCE as required (78, 100, 124, or UNTERM) as required.
7.	If hard copy test results are desired, set the print event criteria using PRINT EVENT, then enable the printer control block (located to the left of the POWER switch) by setting the OFF/ON switch to the ON position.
8.	Connect the FIREBERD 6000 to the equipment under test using the appropriate cables.
9.	Illuminate the RTS and DTR switches located just above the POWER switch to set both signaling leads to HIGH.
10.	Check that the SYNC LED located at the upper right-hand corner of the FIREBERD 6000 is illuminated.  <b>RESULT:</b> The FIREBERD has achieved pattern synchronization, and is gathering test results.

#### **6.2.4 End-to-End Testing**

Figure 6-3 shows two FIREBERD 6000s, each equipped with the RS-449/530/MIL Interface. FIREBERD #1 connects to the 256 kb/s substrate channel of the multiplexer at the near end. FIREBERD #2 connects to the 256 kb/s sub-rate channel

of the multiplexer at the far end. Both instruments simultaneously generate test data and analyze received data for errors in both directions.

The test results obtained in this configuration reflect the quality of all the lines and equipment between the two FIREBERDS.

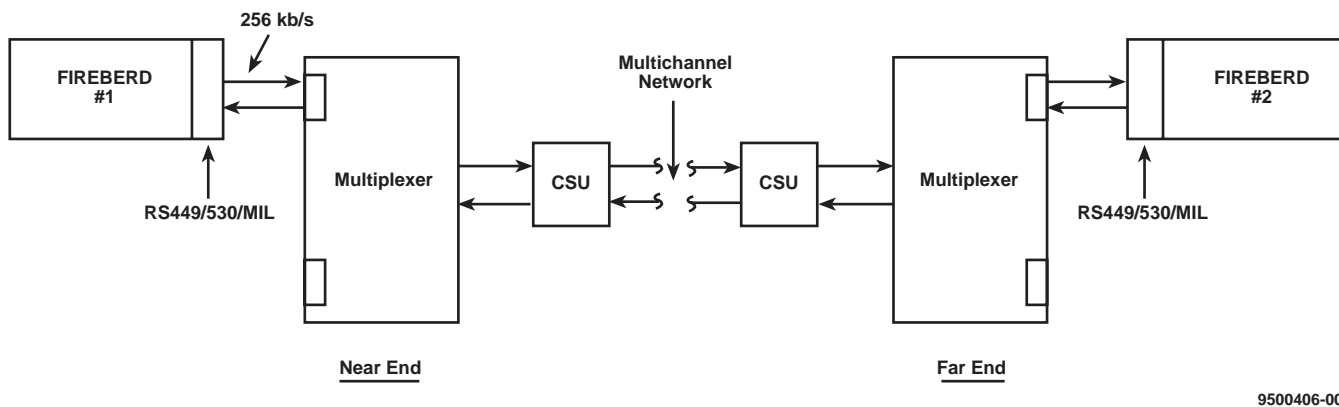

9500406-00

**Figure 6-3**  
**Testing Near- and Far-End Subrate Equipment Simultaneously**

### 6.2.5 End-to-End Synchronous Test Set-Up

Table 6-2 describes the FIREBERD 6000 set-up procedures for the bit error rate test illustrated in Figure 6-3. Although these procedures specifically apply to the testing of

modems and multiplexers using the RS-449 connector, you can use them to set up any basic synchronous test using the RS-449/530/MIL Interface.

**Table 6-2**  
**FIREBERD 6000 Synchronous Test Set-Up With RS-449**

Step	Activity
1.	With the power to the FIREBERD 6000 turned off, insert the RS-449/530/MIL Data Interface in the designated rear-panel slot.
2.	Press the POWER switch to apply power to the FIREBERD 6000.  <b>RESULT:</b> The SETUP display shows the units current configuration.  <b>NOTE:</b> If the FIREBERD 6000 is in Self-Loop mode after power-up, disengage the SELF LOOP switch.
3.	Set the DATA switch to either the 511 or the 2047 data pattern if transmitting test data to either the local modem or the remote modem. If testing a 256 kb/s subrate channel as shown in Figure 6-3 it is recommended to select 511 or 2047 as the data pattern.
4.	Set the GEN CLK switch to the INTF position to receive the clock from the DCE.
5.	Set the TIMING MODE switch to the SYNC position.
6.	Set the MENU switch to the INTF SETUP position. Configure the RS449/530/MIL Data Interface as follows:

**Table 6-2  
FIREBERD 6000 Synchronous Test Set-Up With RS-449 (Continued)**

Step	Activity
	<p>Select</p> <ol style="list-style-type: none"> <li>1. MIL449 to select the RS-449/530/MIL Interface.</li> <li>2. RS449 to select the type of interface.</li> <li>3. EMULATE to select DTE emulation.</li> <li>4. SIGnaling to POSitive.</li> <li>5. LL (Local Loop) and RL (Remote Loopback) ON or OFF depending on the test.</li> <li>6. Press the up arrow on the MENU keypad.</li> <li>7. MODE to select the mode menu.</li> <li>8. BAL for balanced mode.</li> <li>9. IMPEDANCE as required (78, 100, 124, or UNTERM) as required.</li> </ol> <p>7. If hard copy test results are desired, set the print event criteria using PRINT EVENT, then enable the printer control block (located to the left of the POWER switch) by setting the OFF/ON switch to the ON position.</p> <p>8. Connect the FIREBERD 6000 to the equipment under test using the appropriate cables.</p> <p>9. Illuminate the RTS and DTR switches located just above the POWER switch to set both signaling leads to HIGH.</p> <p>12. If performing a loopback test, establish a loop by performing the procedures which are appropriate for your DCE.</p> <p>10. Check that the SYNC LED located at the upper right-hand corner of the FIREBERD 6000 is illuminated.</p> <p><b>RESULT:</b> The FIREBERD has achieved pattern synchronization, and is gathering test results.</p>

**6.2.6 Synchronous Test Results**

Table 6-3 lists the significant synchronous test results that are available with the RS449/MIL Data Interface. These results can be collected via printer or can be viewed in the RESULTS ANALYSIS display windows.

**6.3 ASYNCHRONOUS TESTING**

**6.3.1 Testing a 1200 b/s Asynchronous Modem (Local Loopback)**

Figure 6-4 shows a FIREBERD 6000 equipped with the RS-449/530/MIL Interface. The instrument is connected to a 1200 b/s modem which has its output looped back to its own input. The FIREBERD 6000 both transmits the test data and analyzes the received data for errors.

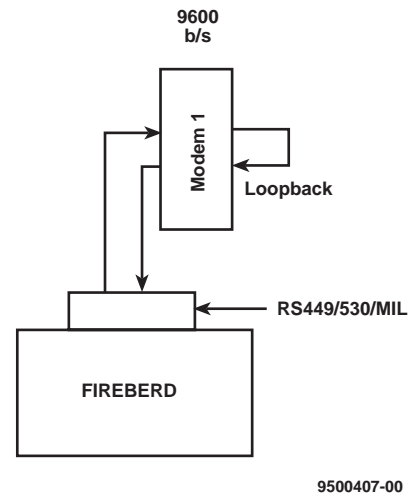

**Figure 6-4  
Testing an Asynchronous Modem**

**Table 6-3  
FIREBERD 6000 Synchronous Test Results**

Category	Results
ERROR	AVG BER AVG BLER BER BIT ERRS BLOCKS BLK ERRS PAT SLIP
PERFORMANCE	G ERR SEC G EFS G %EFS DEG MIN %DEG MIN SES %SES UNA SEC AVL SEC %AVL SEC BER-SES ERR-SES
TIME	ERR EAS EA SEC EF SEC ELAP SEC TIME DATE
SIGNAL	DELAY RCV FREQ GEN FREQ
ALARM	PAT LOSS DAT LOSS CLK LOSS C-D CHA PWR LOSS

**Table 6-4  
FIREBERD 6000 Asynchronous Test Set-Up With 188C**

Step	Activity
1.	With the power to the FIREBERD 6000 turned OFF, insert the RS-449/530/MIL Data Interface in the designated rear-panel slot.
2.	<p>Press the POWER switch to apply power to the FIREBERD 6000.</p> <p><b>RESULT:</b> The SETUP display shows the units current configuration.</p> <p><b>NOTE:</b> If the FIREBERD 6000 is in Self-Loop mode after power-up, disengage the SELF LOOP switch.</p>
3.	Set the DATA switch to the FOX data pattern.
4.	Set the GEN CLK switch to the SYNTH position for the FIREBERD to generate the clock.
5.	Set the TIMING MODE switch to the ASYNC position.
6.	Set the MENU switch to the SYNTH FREQ position. Set the synthesizer frequency to the desired baud rate.
7.	<p>Set the MENU switch to the INTF SETUP position. Configure the RS449/530/MIL Data Interface as follows:</p> <p>Select</p> <ol style="list-style-type: none"> <li>1. MIL449 to select the RS-449/530/MIL Interface.</li> <li>2. 188C to select the type of interface.</li> <li>3. EMULATE to select DTE emulation.</li> <li>4. SIGNALING to POSitive.</li> <li>5. LL (Local Loop) and RL (Remote Loopback) ON or OFF depending on the test.</li> </ol>
8.	Set the MENU switch to the CHAR FORMAT position. Select the desired asynchronous character format: DATA bits, PARITY, and STOP bits.
9.	<p>If a timed test is desired:</p> <ol style="list-style-type: none"> <li>1. Set the MENU switch to TEST INTERVAL.</li> <li>2. Press the MORE key twice, then press the TIMED softkey.</li> <li>3. set the desired test length using the MENU keypad, then press the ENTER key.</li> <li>4. Set the ANALYSIS MODE switch (located to the right of the RESULTS area) to SINGLE.</li> </ol>
10.	<p>If a continuous test is desired:</p> <ol style="list-style-type: none"> <li>1. Set the MENU switch to TEST INTERVAL.</li> <li>2. Set the desired measurement interval (default setting: 104), then press the ENTER key.</li> <li>3. Set the ANALYSIS MODE switch (located to the right of the RESULTS area) to CONTINUOUS.</li> </ol>
11.	If hard copy test results are desired, set the print event criteria using PRINT EVENT, then enable the printer control block (located to the left of the POWER switch) by setting the OFF/ON switch to the ON position.
12.	Connect the FIREBERD 6000 to the equipment under test using the appropriate cables.
13.	Illuminate the RTS and DTR switches located just above the POWER switch to set both signaling leads to HIGH.
14.	If performing a loopback test, establish a loop by performing the procedures which are appropriate for your DCE.
15.	<p>Check that the SYNC LED located at the upper right-hand corner of the FIREBERD 6000 is illuminated.</p> <p><b>RESULT:</b> The FIREBERD has achieved pattern synchronization, and is gathering test results.</p>

### 6.3.2 Asynchronous Test Results

Table 6-5 lists the significant asynchronous test results that are available with the RS449/MIL Data Interface. These results can be collected via printer or can be viewed in the RESULTS ANALYSIS display windows.

**Table 6-5  
FIREBERD 6000 Asynchronous Test Results**

Category	Results	Category	Results
ERROR	BIT ERRS AVG BER BER BLOCKS BLK ERRS AVG BLER CHAR ERR	SIGNAL	DELAY GEN FREQ
		ALARM	DAT LOSS PWR LOSS PAT LOSS
		PERFORMANCE	GERR SEC G EFS G %EFS DEG MIN %DEG MIN SES %SES UNA SEC AVL SEC %AVL SEC PATL SEC %PAT SEC ERR-SES BER-SES
TIME	DATE ERR EAS E A SEC E F EAS ELAP SEC TIME PATL SEC %PAT SEC		



## INTERFACE SPECIFICATIONS

## 7.1 INTRODUCTION

This section contains the specifications for the RS-449/530/MIL Interface Adaptor. This information is listed in Table 7-1.

**Table 7-1**  
**RS-449/530/MIL Data Interface Specifications**

Item	Specification
<p><b>Maximum Speed</b> MIL-188C</p> <p>EIA 530, MIL-188-114, RS-449 Balanced</p> <p>EIA 530, MIL-188-114, RS-449 Unbalanced</p>	<p>64 kb/s synchronous timing 20 kb/s asynchronous timing 64 kb/s recovered timing*</p> <p>15 Mb/s synchronous timing 20 kb/s asynchronous timing 520 kb/s recovered timing*</p> <p>128 kb/s synchronous timing 20 kb/s asynchronous timing 128 kb/s recovered*</p>
<p><b>Normal Data Polarity</b> MIL-188C</p> <p>RS-423/MIL-188-114 UNBAL</p> <p>EIA 530 UNBAL</p> <p>RS-423/MIL-188-114 BAL</p> <p>EIA 530 BAL</p>	<p>MARK (binary "1"): "A" lead positive with respect to signal ground. SPACE (binary "0"): "A" lead negative with respect to signal ground.</p> <p>MARK (binary "1"): "A" lead negative with respect to signal ground SPACE (binary "0"): "A" lead positive with respect to signal ground</p> <p>MARK (binary "1"): "A" lead negative with respect to "B" lead. SPACE (binary "0"): "A" lead positive with respect to "B" lead.</p>
<p><b>Normal Signal Polarity</b> (signal polarity may be inverted)</p> <p>RS-422/MIL-188-114 BAL EIA 530 BAL</p> <p>RS-423/MIL-188-114 UNBAL EIA 530 UNBAL</p>	<p>OFF: "A" lead negative with respect to "B" lead. ON: "A" lead positive with respect to "B" lead.</p> <p>OFF: "A" lead negative with respect to signal ground. ON: "A" lead positive with respect to signal ground.</p>

\*FIREBERD 6000 with clock recovery option

**Table 7-1  
RS-449/530/MIL Data Interface Specifications (Continued)**

Item	Specification
<b>Unbalanced Drivers</b>	
Short circuit current	150 ma max
Output Level (Both states)	0.9V <sub>o</sub> (into 450 Ohms)
Output rise time (clock drivers)	1.2 μs max
Output rise time (signaling drivers)	10 μs typical
Open circuit voltage (V <sub>o</sub> )	5.5 ± .5 volts
<b>Balanced Drivers</b>	
Short circuit current	150 mA max
Differential output signal swing	2 volts min. (with a 100 ohm load)
Output rise and fall time	20 ns max.
Open circuit voltage	6 volts max.
Average DC offset	0V ± 0.4 volts
<b>Receivers</b>	
Termination resistance (specified with fail safe networks)	78 ohms/100 ohms/124 ohms/unterminated (RCV DATA, RCV CLK, EXT TX CLK)
Input Impedance	7.4 k ohm minimum Differential (between A and B)
	6.6 k ohm minimum Single ended A to ground with B grounded
Input threshold	±0.2 volts (A versus B)
<b>Operating Environment</b>	
Operating Temperature	0°C (+32°F) to 50°C (+124°F)
Relative Humidity	10% to 95% (non-condensing)
Storage Temperature	-30°C (-22°F) to 75°C (+167°F)
<b>Shock and Vibration</b>	
Shock	Designed to IEEE 743-1985
Vibration	Designed to IEEE 743-1985
<b>EMI</b>	
	Designed to good commercial practice
<b>Dimensions</b>	
<b>Weight</b>	7.3" (185mm) wide, 1.5" (38mm) high, 5.23" (133mm) deep 13.6 ounces (386 grams)

## MAINTENANCE AND SERVICE

### 8.1 INTRODUCTION

This section contains information on maintenance and service for the RS-449/530/ MIL interface Adapter. It also describes TTC's warranty policies and repair procedures.

### 8.2 MAINTENANCE

#### 8.2.1 In Case of Difficulty

If the unit fails to operate and no front panel indicators illuminate, check the following:

- AC power cord and AC power supply
- AC fuse and fuse size
- Interface clock connection

If some indicators illuminate but the unit fails to operate, verify that the interface in use is the correct type and is properly inserted (turn off power before inserting or removing interface). Check the interface cable and connections to the FIREBERD. Try substituting another interface if one is available.

Follow the self-test procedures in the FIREBERD Operating manual as an aid in localizing the problem. If the unit continues to be inoperative, refer to the following sections for service information or call the TTC Customer Service Department for applications assistance.

**NOTE:** Verify that the interface clock source is connected before attempting self-test.

### 8.3 SERVICE

#### 8.3.1 Warranty Policy

All equipment manufactured by TTC is warranted against defects in material and workmanship. This warranty applies only to the original purchaser and is non-transferable unless express written authorization of the warranty transfer is granted by TTC.

Liability under this warranty extends only to the replacement value of the equipment. The warranty is void if:

- (1) Equipment has been altered or repaired without specific authorization from TTC.
- (2) Equipment is installed or operated other than in accordance with instructions contained in TTC literature and operating manuals.

No other warranty is expressed or implied. TTC is not liable for consequential damages.

#### 8.3.2 In-Warranty Service

Equipment in warranty must be returned to the factory with shipping prepaid. The equipment should be packed and shipping prepaid. The equipment should be packed and shipped in accordance with the instructions in Section 8.3.4 of this manual. Before returning any equipment, the customer must obtain a Return Authorization (RA) number by contacting the TTC Instrument Service Center. The RA number should then appear on all paperwork and be clearly marked on the outside of the shipping container.

After the equipment is repaired by TTC, it will be tested to applicable specifications, burned-in for at least 24 hours, retested, and returned to the customer with shipping prepaid. A brief description of the work performed and the materials used will be provided on the Equipment Repair Report furnished with the returned equipment.

### **8.3.3 Out-Of-Warranty Service**

The procedure for repairing out-of-warranty equipment is the same as that used for equipment still in warranty.

However, there is a minimum charge applied to each request for out-of-warranty service. The minimum charge guarantees the customer an estimate of the repair costs and used as credit against actual materials and labor costs should the equipment be repaired. Contact the TTC Instrument Service Center for specific information on the minimum out-of-warranty repair charge.

The customer will be billed for parts plus standard labor rates in effect at the time of repair. The customer will also be required to furnish a purchase order number before repair work can be started, and a hard copy of the purchase order must be received by TTC before the repaired equipment may be shipped to the customer. A description of the labor and materials used will be provided in the Equipment Repair Report.

Once an out-of-warranty repair is made, the repaired part or component is warranted for 90 days. This warranty applies only to the part or component that was repaired; other parts or components are not covered under the 90-day repair warranty.

### **8.3.4 Equipment Return Instructions**

The customer should attach a tag to all equipment returned for repair that includes the following information:

- (1) Owner name and address.
- (2) A list of equipment being returned and the applicable serial number(s).
- (3) A detailed description of the problem or service requested.
- (4) The name and telephone number of the person to contact regarding questions about the repair.
- (5) The Return Authorization (RA) number.

If possible, the customer should return the equipment using the original shipping container and material. If the original container is not available, the unit should be carefully packed so that it will not be damaged in transit. TTC is not liable for any damage that may occur during shipping. The customer should clearly mark the TTC issued RA number on the outside of the package and ship it prepaid and insured to TTC.

**RS-449/530/MIL DATA INTERFACE FACTORY DEFAULTS**

**Table A-1  
Data Interface Default Settings**

<b>Item</b>	<b>Factory Default</b>
TYPE	RS449
CONNECTOR	D-Type
EMULATE	DTE
MODE	BAL
IMPEDANCE	100 ohms
TIMING	SYNC
DATA BITS	8
PARITY	ODD
STOP BITS	1
RCV CLOCK	AUTO
SIGNALING	
TM	OFF
CTS	OFF
LL	OFF
RL	OFF
SIGNALING	POS

